



INSTRUCTION MANUAL

800W ELECTRIC TILLER

MODEL NO: THET -- PRODUCT NO: 193874002

EN - ORIGINAL INSTRUCTIONS

ASSEMBLY REQUIRED

SAVE THESE INSTRUCTIONS

SPARES & SUPPORT: 01793 333212

FOR YOUR SAFETY

Please read & understand this manual, paying attention to the safety instructions, before use.

Incorrect use of the product could put the operator or machine in danger.

Whilst every effort has been made to ensure the accuracy of information contained in this manual, our policy of continuous improvement determines the right to make modifications without prior warning.

Images used are for illustration purposes only

Copyright Notice

Copyright © Handy Distribution

Permission is granted to reproduce this publication for personal & educational use only.

Commercial copying, redistribution, hiring or lending is prohibited.

No part of this publication may be stored in a retrieval system or transmitted in any other form or means without written permission from Handy Distribution.

In all cases this copyright notice must remain intact.

CONTENTS

SPECIFICATIONS

IMPORTANT INFORMATION

GENERAL SAFETY INSTRUCTIONS

COMPONENTS

ASSEMBLY

OPERATION

MAINTENANCE

TROUBLE SHOOTING

PARTS DIAGRAMS & LISTS

WARRANTY

EC DECLARATION OF CONFORMITY

ASSEMBLY IS REQUIRED

This product requires assembly before use. See the "Assembly" section for instructions.

Please check that all parts required for the assembly of this spreader are included. If for any reason you believe a part for the assembly is missing or damaged, please contact us.

**If you require any assistance with regards to the contents or operation of
your machine, please contact us:**

TEL: 01793 333212

**EMAIL: customerservice@handydistribution.co.uk
(MON – FRI 8.00AM TO 5.30PM EXCL. BANK HOLIDAYS)**

SPECIFICATIONS

The manufacturer reserves the right to change the product specification and livery according to continued product improvements.

Model	THET
Product Number	193874002
Motor	AC 230v, 50Hz, 800W
Protection	Class II – IPX4 
Idle Speed	400 min ⁻¹
Tilling Width	30 cm
Tilling Depth	20 cm
Noise Pressure Level (LPA)	73.6dB(A) K=2.5dB(A)
Guaranteed Noise Power Level (LWA)	93.0 dB(A)
Vibration	ah 1.131m/s ² K=1.5m/s ²
Net Weight	8.5kg

IMPORTANT INFORMATION

INTENDED USE

The product is intended for domestic gardens. This product is not intended for commercial use. Generally acknowledged accident prevention regulations and enclosed safety instructions must be observed. Only perform work described in these instructions for use, any other use is incorrect. The manufacturer will not assume responsibility for damage resulting from such use.

GENERAL SAFETY INSTRUCTIONS

Read and understand the owner's manual and labels affixed to the product. Learn its application and limitations as well as the specific potential hazards. Retain these instructions for future reference. The operator is responsible for following the warnings & instructions in this manual and on the product.

STAY ALERT

Do not operate the machine while under the influence of drugs, alcohol, or any medication that could affect your ability to use it properly. Do not use this machine when you are tired or distracted from the job at hand. Be aware of what you are doing at all times. Use common sense.

USERS

Never allow children or people unfamiliar with these instructions to use the machine. Local regulations can restrict the age of the operator.

AVOID DANGEROUS CONDITIONS

Work in daylight or in good artificial light; always be sure of your footing on slopes; walk, never run with the machine; exercise extreme caution when changing direction on slopes; do not work on excessively steep slopes; use extreme caution when reversing or pulling the machine towards you; do not put hands or feet near or under rotating parts.

INSPECT YOUR MACHINE

Check all bolts, nuts, and screws for tightness before each use, especially those securing guards and drive mechanisms. Vibration during use, may cause these to loosen.

Form a habit of checking to see that all other tools/equipment are removed from the working area before turning it on.

Replace damaged, missing or failed parts before using it. Warning labels carry important information. Replace any missing or damaged warning labels.

DRESS PROPERLY

Do not wear loose clothing, gloves, scarfs, neckties or jewellery (rings, wrist watches), which can be caught in moving parts. Always wear long trousers. Always wear substantial non slip, substantial or heavy-duty safety footwear are highly recommended when working. Never operate barefoot or when wearing sandals. Wear a

face or dust mask if the operation is dusty. Always wear safety glasses/goggles and/or face shields. Everyday eyeglasses have only impact resistant lenses; they are not safety glasses/goggles. Wear protective hair covering to contain long hair, preventing it from getting caught in machinery.

AVOID ELECTRICAL SHOCK

Do not operate near underground electrical cables, telephone lines, pipes or hoses.

ALWAYS SWITCH THE MACHINE OFF

Always switch off the machine, disconnect the plug and wait for the tines to stop turning before carrying out any inspection or maintenance. The tines will not stop immediately after switching off.

ELECTRICAL SAFETY

The mains voltage must correspond to the one marked on the technical data plate (230V-50Hz). Do not use any other source of power. The use of a circuit breaker is recommended for an intervention range of 10 to 30 rated mA.

Make sure you always know where the cable is and never pass the tiller over the cable to avoid cutting the cable with the tines.

Do NOT use the machine in the rain and do NOT leave it outside overnight. Try to prevent it getting wet or being exposed to humidity.

Check the power cable regularly to ensure it is not damaged. Only use an extension cable which is suitable for outdoor use. If the cable is damaged arrange for a replacement before further use.

The mobile socket of the extension cable should be splash proof in compliance with DIN57282 and VDE 0282 regulations; the cross section of the wire (max length 75m) should be at least 1.5mm². Use H07RN-F harmonised cable.

KEEP BYSTANDERS AND CHILDREN AWAY

Keep unauthorised persons a minimum distance of 20 metres away from the machine. If approached, stop the machine immediately. Do not allow children to handle, climb on or use the machine. Keep in mind the operator or user is responsible for accidents or hazards occurring to other people or their property.

DO NOT OVERREACH

Keep proper footing and balance at all times when using the machine. Use on slopes with great care. Never stand on the machine. Serious injury could occur if the machine is tipped or if the moving parts are unintentionally contacted. Do not store anything above or near the machine, where anyone might stand on the machine to reach them.

AVOID INJURY FROM UNEXPECTED ACCIDENT

Keep hands & feet out of the way of all moving parts. Do not place any part of your body or any tool e.g. in the machine during operation.

DO NOT FORCE TOOL

Always work within the rated capacity. Do not use machine for a purpose for which it was not intended.

NEVER LEAVE MACHINE RUNNING UNATTENDED

Do not leave the machine unattended until it has come to a complete stop.

INSPECT

Before using, always visually inspect to see that the tools are not worn or damaged. Replace worn or damaged elements and bolts in sets, to preserve balance.

MAINTAIN YOUR MACHINE WITH CARE

Clean the machine immediately after use. Keep the machine clean to ensure it operates to its full and safest performance. When maintaining this machine, only the manufacturer's original replacement parts should be used. The use of non-original manufacturer parts may invalidate your warranty.











PROTECT THE ENVIRONMENT

Take left over materials to an authorised collection point or follow the stipulations in the country where the mixer is used. Do not discharge into drains, soil or water.

STORE IDLE EQUIPMENT

When not in use, the machine should be stored in a dry location. Keep the machine away from children and others not qualified to use it.

SAFETY SYMBOLS

	<p>Read & understand operator's manual before using the machine. Failure to follow instructions could result in death or serious injury.</p>		<p>Always inspect the machine thoroughly before turning it on. Keep guards in place and in working order. Do not use the machine with the electric motor cover removed.</p>
	<p>Whenever the machine is in use, safety glasses must be worn to safeguard against flying objects. Wear gloves to protect your hands and ear protection. Wear foot protection at all times.</p>		<p>Keep all bystanders & animals at least 20 metres away from the machine during operation. If approached, stop the machine immediately.</p>
	<p>Keep hands & feet out of the way of all moving parts. Do not place any part of your body or any tool in the tines during operation.</p>		<p>Remove the electrical plug from the power source before undertaking our checks, servicing or repairs.</p>
	<p>Acoustic power level LWA accordance with directive 2000/14/EC + 2005/88/EC (Please see machine & specification within this manual for actual reading)</p>		<p>Safety alert symbol. Used to alert you to potential personal injury hazards. Obey all safety messages that follow this symbol to avoid possible injury.</p>
 <p>DANGER</p>	<p>Indicates an imminently hazardous situation which, if not avoided, will result in serious injury.</p>	 <p>WARNING</p>	<p>Indicates a potentially hazardous situation which, if not avoided, could result in serious injury.</p>
 <p>CAUTION</p>	<p>Indicates a potentially hazardous situation which, if not avoided, may result in minor or moderate injury.</p>	<p>CAUTION</p>	<p>Used without the safety alert symbol indicates a potentially hazardous situation which, if not avoided, may result in property damage.</p>

COMPONENTS

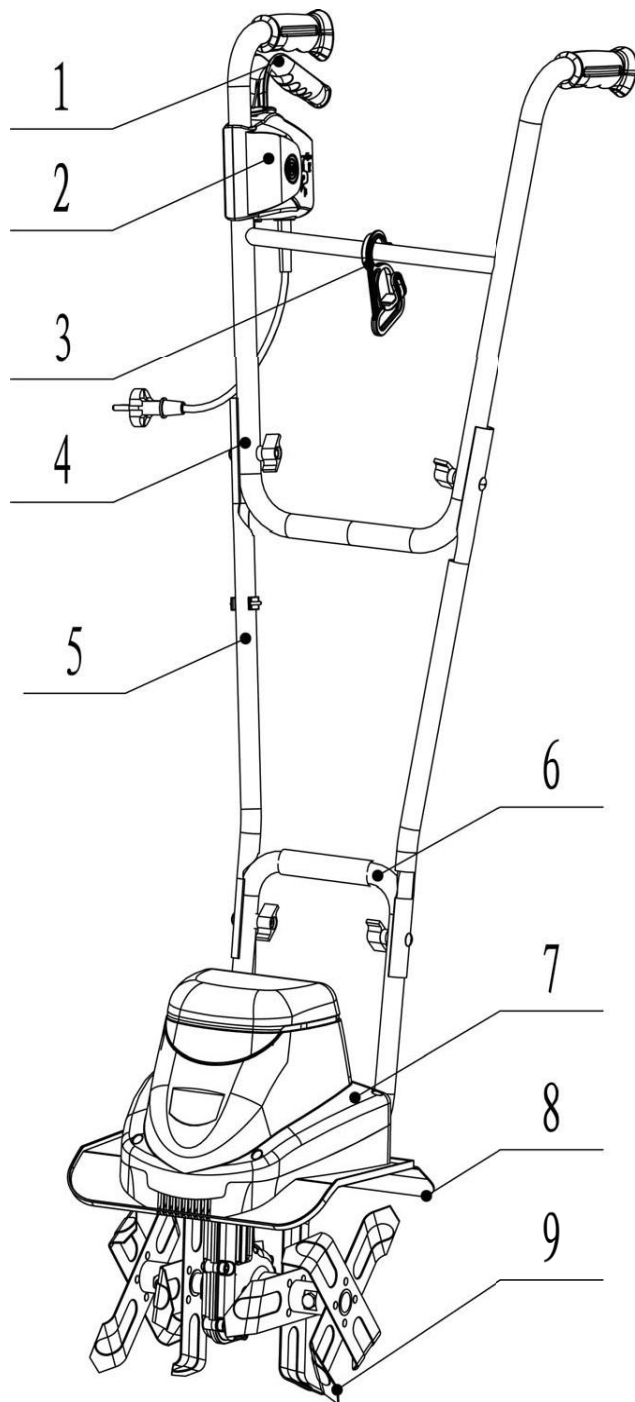

1	Trigger Lever
2	Safety Switch
3	Cable Relief
4	Upper Handle
5	Carrying Handle
6	Lower Handle
7	Fender
8	Protective Shield
9	Tines

ASSEMBLY

Before commencing assembly, unpack the contents of the box and check that nothing is damaged. You will require a Phillips (crosshead) screwdriver and an 8mm spanner.

HANDLEBARS

- Remove the two black crosshead screws from the Trigger switchbox. Remove the small switchbox housing. Attach the Trigger switchbox to the Upper Handle, by placing the attached lugs in the handle holes, on the right-hand side. Re-attach the small housing onto the outside of the upper handle and secure using the two black crosshead screws.
- Attach the Middle Handles to the Lower Handle Frame and fasten with the two handle knobs, and bolts. The handle knob should be located on the inside with the bolt on the outside of the handlebars.
- Repeat the above process, when attaching the Upper Handle to the Middle Handles.
- Take care not to pinch the electric cable or switch wires.
- Secure the wires to the handle, using the black cable clips.
- Ensure the handle knobs are secured in place.

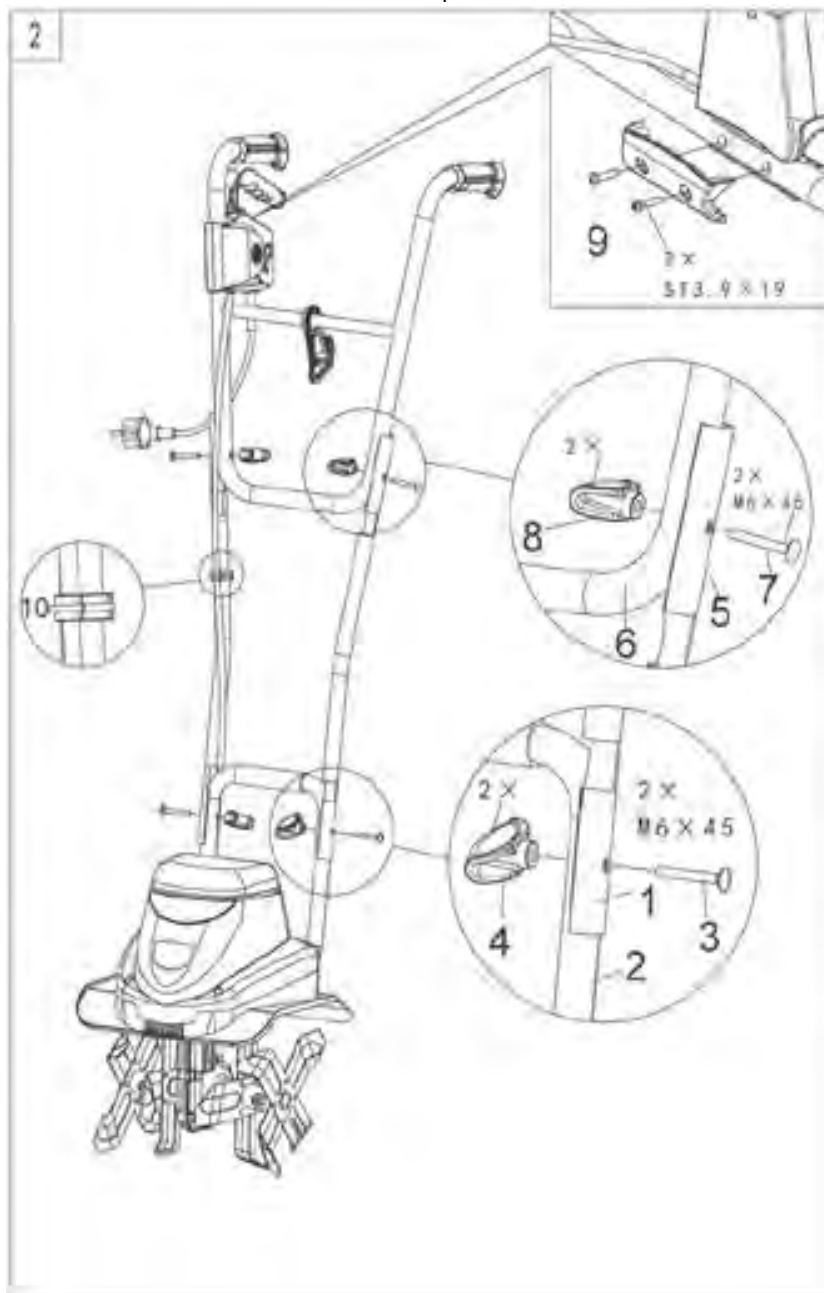

OPERATION

Move the tiller to the work area before starting the motor.

GEARBOX LUBRICATION

Grease is supplied in the machines gearbox at the factory.

High quality automotive grease should be applied to the gearbox every 2 years.

The gearbox holds a maximum of 60ml of grease.

Regularly check for leaks coming from the gearbox.

STARTING THE MACHINE:

- Plug the machine into the mains. If using an extension cable, please check that it meets the necessary requirements, as stated in this manual.
- When you are at your working area, press the Safety Button on the Trigger Switchbox with your thumb. Squeeze the green Trigger, up towards handle assembly.
- The tines will now rotate.
- With the tines rotating, release the Safety Button with the Trigger still squeezed.
- To stop, release the Trigger



CAUTION

The tines will still rotate, after trigger has been released.

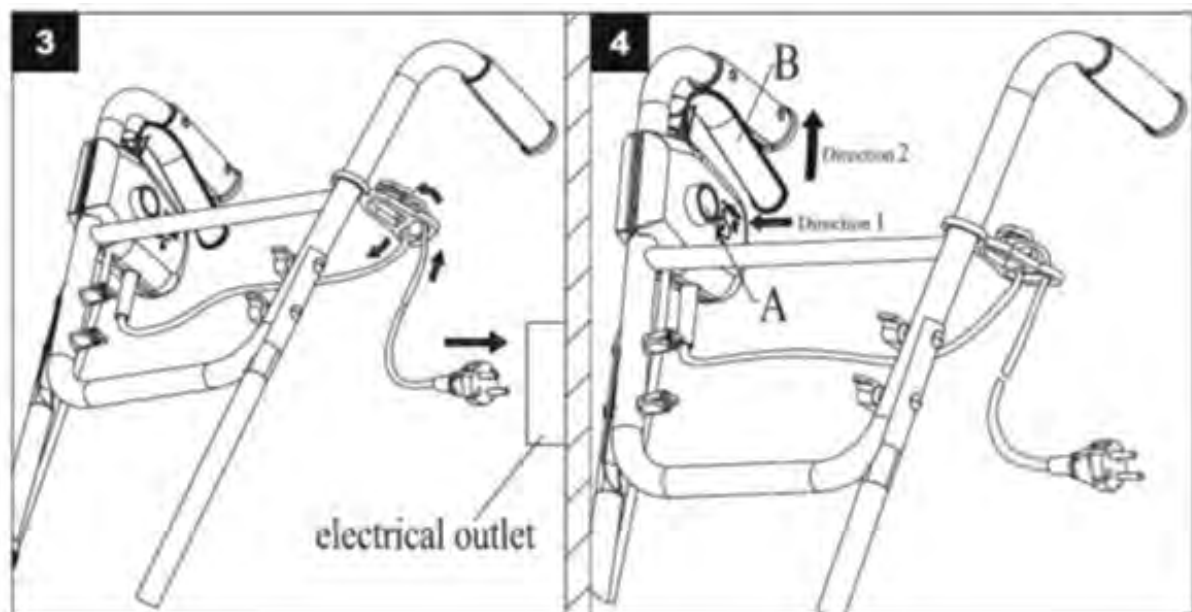

USING THE MACHINE

- Hold the tiller firmly when switching on as it may jump when the tines start rotating.
- The rotating tines will pull the tiller forward, press down on the handle to dig the tines into the soil.
- By pulling the tiller backwards the tines will dig deeper and more aggressively, take care not to trip over and keep the cable clear.
- For breaking sod or deep tilling, allow the tines to move forward to arms reach and then pull back firmly. By repeatedly allowing the tiller to move forward and backward, cultivating will be more effective.
- If the tiller digs deep enough to stay in one spot, rock gently from side to side to move the tiller forward.
- Take care when transporting the machine. Always carry the tiller to avoid causing damage to the tines when moving over hard ground.
- Switch off the power and clear the tines of all debris, roots, stones etc. regularly when using. If weeds are wrapped round the tines, you may have to remove the tines as shown later in this manual.

- For preparing seed beds, we recommend you use one of the patterns shown below. Either make two passes at right angles to each other, or make two passes, side by side with the second overlapping the first.

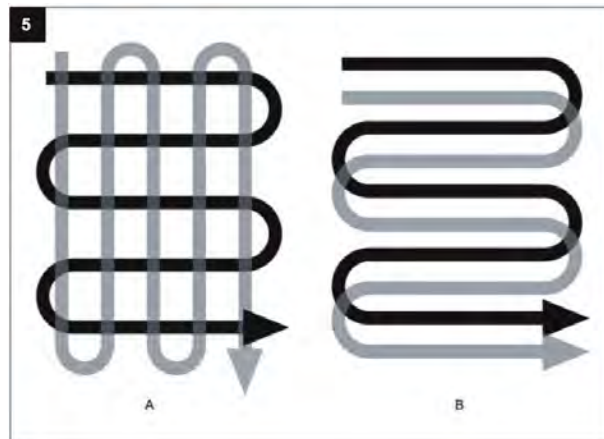

MAINTENANCE

BEFORE CARRYING OUT ANY MAINTENANCE, DISCONNECT THE MACHINE FROM THE POWER SOURCE.

Keeping your tiller in top running condition will prolong its life and help you obtain optimum performance whenever you wish to till your garden.

CLEANING

Clean the tiller underneath the tine shield after each use. It is easier to clean off soon after use before it has had time to dry. Let it to cool down before cleaning off the tines with a stiff brush.

Ensure all vents are clear of debris, dirt or grass. **(DO NOT SPLASH WITH WATER).**

ONLY USE MANUFACTURER APPROVED PARTS

If a part needs replacing, only use the manufacturer's original parts. Non-original replacement parts will invalidate your warranty and may result in a safety hazard or poor operation.

STORAGE

The tiller should be stored in a dry area, out of the reach of children.

At the end of the season, or the tiller is not going to be used for some time:

- Clean the tiller.
- Wipe over the metal surfaces with an oil-impregnated cloth to protect them from corrosion (non-resinous oil) or spray a fine coat of oil onto them from a can.
- Fold the top handle down for ease of storage, checking the cables are not crimped in the handle assembly.

CHECKING TRANSMISSION LUBRICANT

- The drain screw plug is located on the right side of the transmission housing.
- Lay the tiller on its left side & clean the transmission of dirt and debris. If necessary, disassemble the tines.
- Remove the drain screw, using a 5mm Allen key to unscrew the plug.
- Fill up using a grease gun & a high quality automotive grade grease until it begins to seep out around the edge of the hole of the nozzle. From empty, 60ml of grease will fill gearbox.
- Reinstall the drain screw plug.

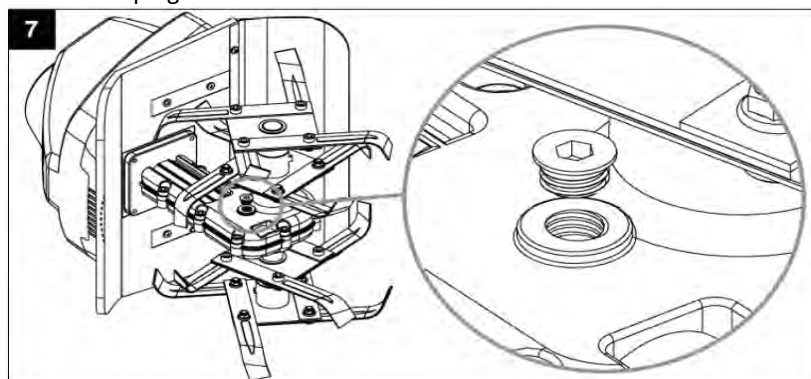

ADJUSTING AND CHANGING THE TINES

Worn tines can result in poor performance and overload the motor. Sharpen or replace tines with new ones if necessary. To remove tines:

- Remove the lock pin from the end of the shaft.
- Take off the outer tine set from the shaft.
- Remove the lock pin and take off the inner tine set from the shaft.
- Reverse above steps to install tines.

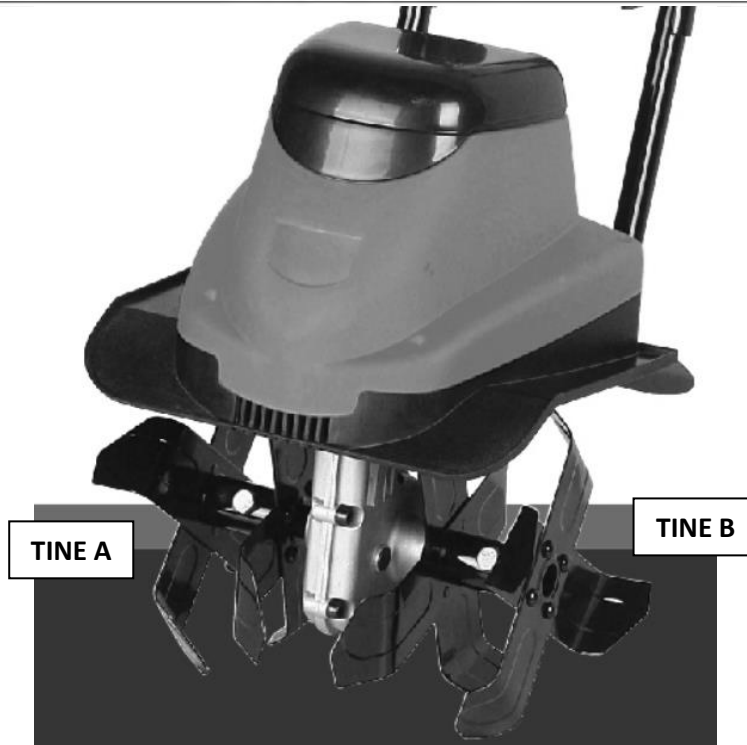
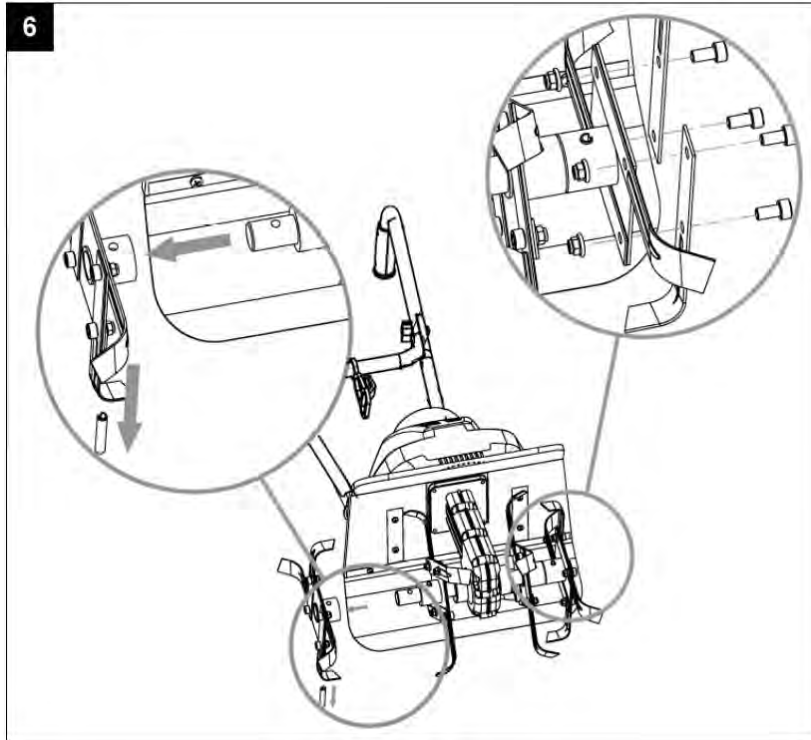

When assembling the blades, the shape angle should touch the earth.

TROUBLE SHOOTING

ISSUE	LIKELY CAUSE	SOLUTION
Motor does not start	No Electricity	Check mains connection
	Defective Cable	Check cable, replace if necessary or repair if possible. Should only be carried out by electrical specialist.
	Defective safety switch or plug	Arrange for inspection by electrical or garden machinery specialist.
	Overheat protection activated	Blades blocked
Soil too hard – move tiller forward/backward several times slowing down the tine speed. Allow motor to cool down before restarting.		
Abnormal Noises	Blade jammed	Switch the machine off, remove from the mains. When the blades completely stopped, remove the foreign object.
	Lack of lubrication	Top up gearbox grease if necessary. Alternatively, if leaking, have machine inspected by garden machinery specialist.
	Loose bolts, nuts or other securing components	Tighten all components, contact garden machinery specialist if continues.
Abnormal Vibration	Tines damaged or worn	Replace or have the tines checked by garden machinery specialist
Poor results	Worn tines	Replace or have the tines checked by garden machinery specialist

PARTS DIAGRAM - MACHINE

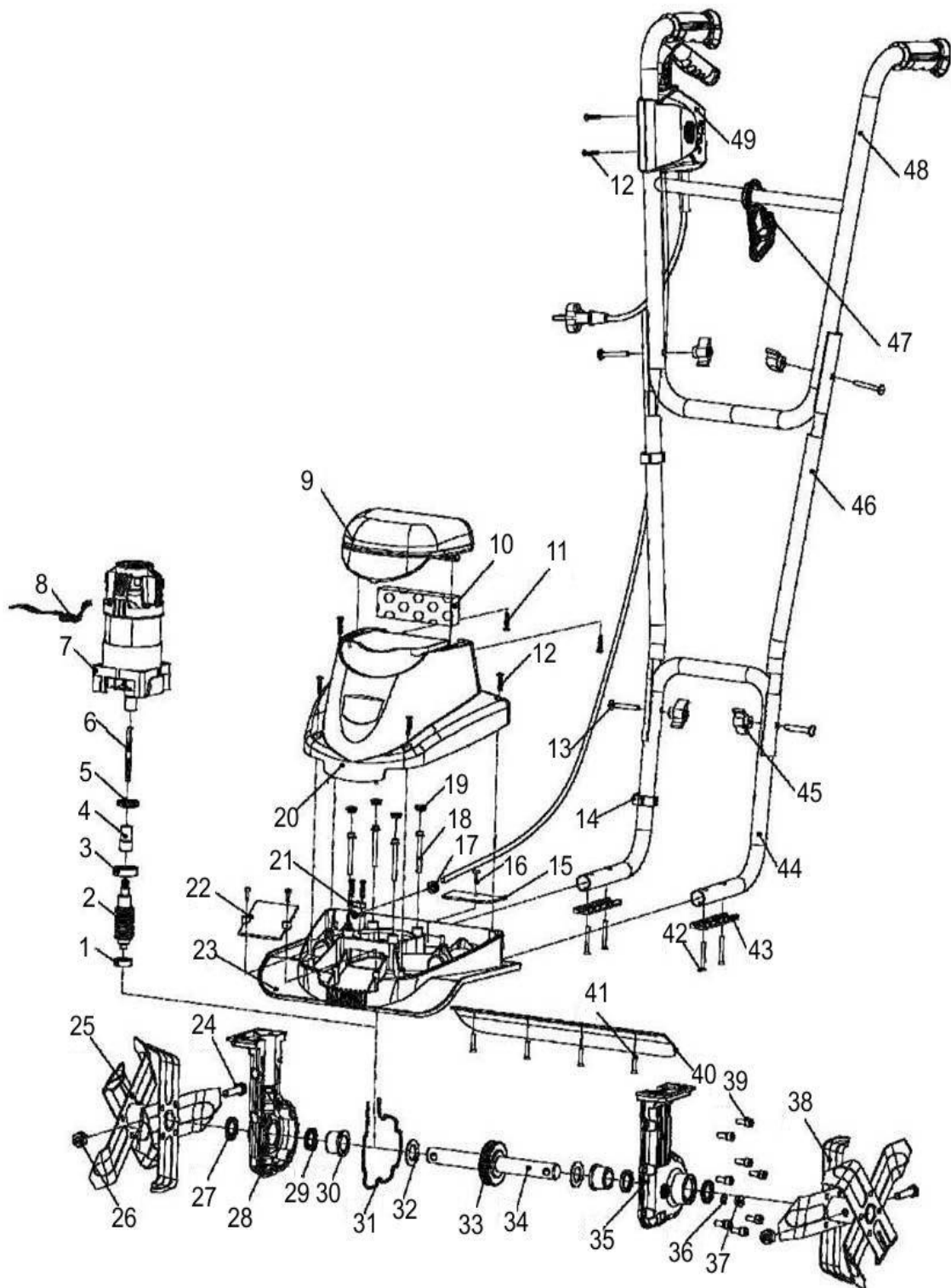

NOTE: Parts Lists are supplied for information purposes only, not all parts are stocked individually & we recommend you contact our Spares Team on 01793 333212 for expert advice.

PARTS LIST

No.	Part No.	Description	QTY
1	TH165-1	Bearing 608Z	1
2	TH165-2	Worm Shaft	1
3	TH165-3	Bearing 6200	1
4	TH165-4	Coupler	1
5	TH165-5	Rubber Seal 2	1
6	TH165-6	Flexible Shaft	1
7	TH165-7	Motor	1
8	TH165-8	Inductor	1
9	TH165-9	Cover	1
10	TH165-10	Sponge Strip	1
11	TH165-11	Screw ST3.5x16	4
12	TH165-12	Screw ST3.9x19	14
13	TH165-13	Screw M6x45	4
14	TH165-14	Cable Clip	2
15	TH165-15	Back Cover	1
16	TH165-16	Screw ST3x12	1
17	TH165-17	Cable Sleeve	1
18	TH165-18	Screw M5x48	4
19	TH165-19	Capping Plug	4
20	TH165-20GM	Motor Housing	1
21	TH165-21	Cable Holder	1
22	TH165-22	Cover	1
23	TH165-23	Fender	1
24	TH165-24	Screw M8x40	2
25	TH165-25	Tines Set 2	1

No	Part No.	Description	QTY
26	TH165-26	Nut M8	2
27	TH165-27	Ring	2
28	TH165-28	Gearbox Case Right	1
29	TH165-29	Rubber Seal	2
30	TH165-30	Oil Bearing	2
31	TH165-31	Seal	1
32	TH165-32	Washer	2
33	TH165-33	Worm Wheel	1
34	TH165-34	Shaft	1
35	TH165-35	Gearbox Case Left	1
36	TH165-36	O-Ring	1
37	TH165-37	Drain Plug	1
38	TH165-38	Tines Set 1	1
39	TH165-39	Screw M6x16	6
40	TH165-40	Protective Shield	1
41	TH165-41	Screw ST4.2x19	4
42	TH165-42	Screw ST4.2x32	4
43	TH165-43	Handle Holder	2
44	TH165-44GM	Lower Handle	1
45	TH165-45	Handle Nut	4
46	TH165-46GM	Middle Handle	2
47	TH165-47	Cable Hook	1
48	TH165-48GM	Upper Handle	1
49	TH165-49	Trigger & Safety Switch	1

NOTE: Parts Lists are supplied for information purposes only, not all parts are stocked individually & we recommend you contact our Spares Team on 01793 333212 for expert advice.

WIRING DIAGRAM

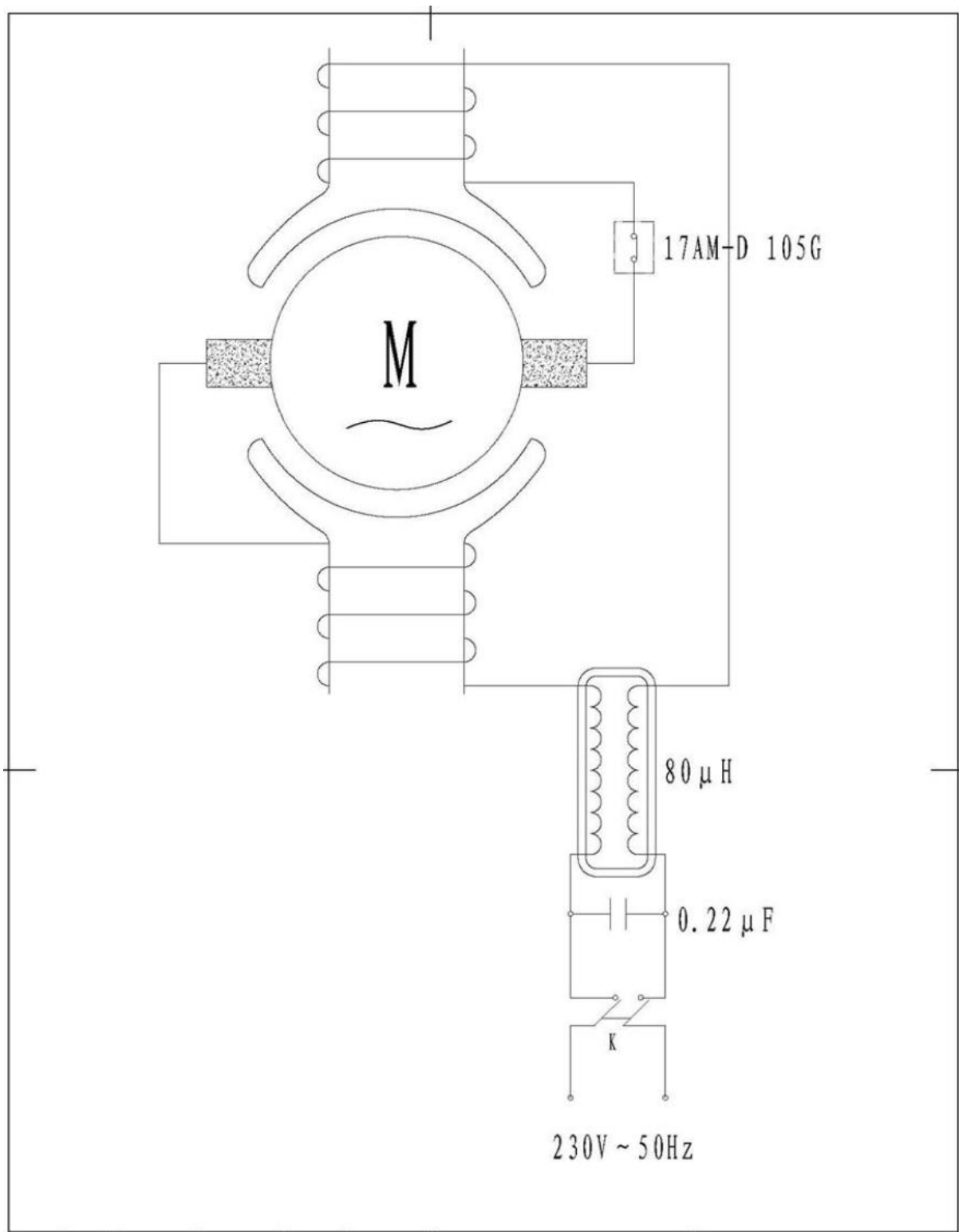

GJ HANDY & CO LTD USER WARRANTY POLICY

Users Statement of Warranty

Each new machine is warranted against defective material or assembly of material under normal usage. The warranty applies to the original purchaser and covers faulty parts and the labour involved in replacing and repairing those parts, which are of original manufacture.

Period of Warranty

Webb (excludes Electric Handheld & Dynamic)

Webb Pro

Sanli Engine

- a) 2 years from the original date of sale to the first domestic user.
- b) 90 days from the original date of sale to the professional/commercial user.
- c) 90 days from the original date of sale when used for hire.
- d) A reduced warranty period of 90 days applies to those items which are subject to normal wear and tear (e.g. but not limited to wheels, tyres, cutter bars, cylinders, cutting blades, blade boss, belts, cables, nylon line & spool, collection bags, spark plugs).
- e) Engines are supplied with a separate warranty to the machine. The engine manufacturers warranty statement which will be supplied within the engine instruction manual. All enquiries and warranty repairs should be discussed with the engine manufacturer or approved warranty repair dealer.
- f) 90 days from the original date of purchase for Replacement Spare Parts (unless normal wear & tear component, which are covered for 30 days).
- g) All machines' must be serviced within the first 12 months from the original date of purchase to comply with the warranty, failure to do so will invalidate the 2nd year of the warranty.

All warranty repairs must be undertaken by an authorised service dealer. These dealers have been accredited by GJ Handy & Co Ltd and agree to only use genuine parts and follow our repair procedures.

Webb Electric Handheld

Webb Dynamic

Handy

Mowerland

Q-Garden

- a) 1 year from the original date of sale to the first domestic user.
- b) 90 days from the original date of sale to the professional/commercial user.
- c) 90 days from the original date of sale when used for hire.
- d) A reduced warranty period of 90 days applies to those items which are subject to normal wear and tear (e.g. but not limited to wheels, tyres, cutter bars, cylinders, cutting blades, blade boss, belts, cables, nylon line & spool, collection bags, spark plugs).
- e) Engines are supplied with a separate warranty to the machine. The engine manufacturers warranty statement which will be supplied within the engine instruction manual. All enquiries and warranty repairs should be discussed with the engine manufacturer or approved warranty repair dealer.
- f) 90 days from the original date of purchase for Replacement Spare Parts (unless normal wear & tear component, which are covered for 30 days).

All warranty repairs must be undertaken by an authorised service dealer. These dealers have been accredited by GJ Handy & Co Ltd and agree to only use genuine parts and follow our repair procedures.

GJ HANDY & CO LTD USER WARRANTY POLICY

Not covered by this warranty

- a) The warranty policy does not cover any depreciation or damages caused by ordinary wear, rusting or corrosion, lack of correct maintenance or operation, misuse, abuse, lack of transportation or accident.
- b) The warranty policy does not cover any costs necessary for the standard periodic maintenance services instructed by the operator's manual, or service parts replacement which would include oil, filters, tyres, belts, brake linings, fuses, blades, seals and other service parts unless it can be proven that the item has evidence of faulty manufacture.
- c) The warranty policy will not cover failure or damage caused as a result of parts or accessories being modified without the written approval of GJ Handy & Co Ltd.
- d) The warranty policy will not cover the unit if non-genuine parts have been fitted and as a result damage has occurred to the unit.
- e) The warranty policy is non-transferable and is only applicable to the original purchaser.

Disclaimer

- a) This warranty is only a remedy for defect of products. GJ Handy & Co Ltd will never warranty in terms of the merchantability or the fitness for a particular purpose.
- b) No person is authorised to make any warranties, representations or promises, expressed or implied, on behalf of GJ Handy & Co Ltd, or to modify the terms conditions or limitation of this warranty policy in any way.
- c) Neither GJ Handy & Co Ltd nor any company affiliated with GJ Handy & Co Ltd shall be liable in any event or manner whatsoever for incidental or consequential damages or injuries, including, but not limited to, loss of crops, loss of profit, out of pocket expenses or profits, rental of substitute equipment or other commercial losses.

General

- a) Most warrantable failures show up within the first few weeks of use. These failures are usually straightforward and warranty assessment is relatively easy.
- b) Failures relating to cutter decks and belts need careful investigation, as the cause may not always be straightforward. Look for damage to blades and pulleys especially when the cutter belt or blade boss have snapped or cracked as this could be due to impact damage.
- c) Customers should always refer to the operator/instruction manual when any disputed problem arises, you will find most areas covered within the manual.

Handy

EC DECLARATION OF CONFORMITY

We Handy Distribution Ltd - SN3 5HY (Importer) declare that the product:

Designation: 800watt Electric Tiller

Model(s): THET-A

Product Number: 193874002

Type/Serial No. As per rating label on machine

Complies with the following directives:

2006/42/EC - Machinery Directive

Standards and technical specifications referred to:

EN 55014-1:2006+A1+A2, EN 55014-2:1997+A1+A2, EN 61000-3-2:2006+A1+A2, EN 61000-3-3:2013, EN 60335-1:2012, EN 709:1997+A4, EN 62233:2008, ZEK 01.4-08/11.11

Name of the Notified Body:

TÜV Rheinland LGA Products GmbH

Address:

Tillystrabe 2, 90431 Nürnberg

Measured Noise Pressure Level: LPA 73.6dB(A) K=2.5dB(A)

Guaranteed Noise Power Level: LWA 93.0 dB (A)

Vibration Level: ah 1.131m/s² K=1.5m/s²

Authorised signatory and technical file holder

Date: 04/12/2018



Signature:

Name: Mr Simon Belcher

Position: Chairman

Company: Handy Distribution Ltd

Address: Murdock Rd, Swindon, Wiltshire, SN3 5HY.



**For spares or support of your handy product,
please contact us:**

Tel: 01793 333212

**Email: customerservice@handydistribution.co.uk
(Mon – Fri 8.00am to 5.30pm excl. Bank Holidays)**

To see our range of garden machinery & equipment visit:

www.thehandy.co.uk

Making gardening easier & affordable since 1938

Distributed by Handy Distribution, Murdock Road, Dorcan, Swindon, SN3 5HY