



INSTRUCTION MANUAL

GARDEN TROLLEY

MODEL NO: THGT -- PRODUCT NO: 193854001

EN - ORIGINAL INSTRUCTIONS

ASSEMBLY REQUIRED - MINIMUM TWO PERSONS

SAVE THESE INSTRUCTIONS

SPARES & SUPPORT: 01793 333212

FOR YOUR SAFETY

WARNING: PERSONS SHOULD NEVER RIDE IN THE GARDEN TROLLEY.

Please read & understand this manual, paying attention to the safety instructions, before use.

Incorrect use of the product could put the operator or machine in danger.

Whilst every effort has been made to ensure the accuracy of information contained in this manual, our policy of continuous improvement determines the right to make modifications without prior warning.

Images used are for illustration purposes only.

Copyright Notice

Copyright © Handy Distribution

Permission is granted to reproduce this publication for personal & educational use only.

Commercial copying, redistribution, hiring or lending is prohibited.

No part of this publication may be stored in a retrieval system or transmitted in any other form or means without written permission from Handy Distribution.

In all cases this copyright notice must remain intact.

CONTENTS

SPECIFICATION

IMPORTANT INFORMATION

GENERAL SAFETY INSTRUCTIONS

SET UP & PREPARATION FOR OPERATION

ASSEMBLY

OPERATION

MAINTENANCE & STORAGE

TROUBLE SHOOTING

PARTS DIAGRAM & LIST

WARRANTY

ASSEMBLY IS REQUIRED - MINIMUM TWO PERSONS

- This product requires assembly before use.
- See "Assembly" section for instructions.
- Because of the weight and/or size of the machine, it is recommended that another adult is present to assist with the assembly.
- Inspect all components closely upon receipt to make sure no items are missing or damaged.

If you require assistance with regards to the contents or operation of the machine, please contact us:

TEL: 01793 333212

EMAIL: customerservice@handydistribution.co.uk

(MON – FRI 8.00AM TO 5.00PM EXCL. BANK HOLIDAYS)

SPECIFICATION

The manufacturer reserves the right to change the product specification and livery according to continued product improvements.

Model	THGT
Product No.	193854001
Load Capacity (kgs)	200 (440lb)
Overall Dimensions (cm)	109(L) 51(W) 60(H) (exc. draw bar handle)
Internal Bed Dimensions (cm)	94(L) 48(W) 25(H)
Tyre Size	10x4.10/3.50-4
Tyre	Puncture-less

IMPORTANT INFORMATION

INTENDED USAGE



WARNING

Persons should never ride in the garden trolley

The Garden Trolley is designed for use in private gardens and primarily used around **GRASS OR LAWN AREAS**, but not in public facilities, parks or sports grounds and not for agricultural or forestry use. Never exceed the rated load capacity of 200kg (440lb).

This is a garden trolley, therefore extended use over abrasive surfaces (e.g. concrete, tarmac etc.) could cause premature wear on the trolley tyres. Commercial or industrial environments are not recommended. Not to be used on public highways or roads. When operating with a tractor, do not exceed 10mph.

Generally acknowledged accident prevention regulations and enclosed safety instructions must be observed. Only perform work described in these instructions for use, any other use is incorrect. The manufacturer will not assume responsibility for damage resulting from such use.



WARNING

Read this instruction manual carefully before operating this machine. Make sure that you are familiar with the controls and properly operate the machine. Following these instructions can reduce the risk of personal injury.

IF NOT USED PROPERLY THIS MACHINE CAN BE DANGEROUS!

This machine can cause serious injury to the operator and others, the warning and safety instructions must be followed to ensure reasonable safety and efficiency in using this product. The operator is responsible for following the warning and safety instructions in this manual and on the machine. Never use the product unless the components are correctly positioned and operational.

TRAINING

Read the instructions carefully: Be familiar with the controls and the proper use of the equipment.









Never allow children or people unfamiliar with these instructions to use the product.

Local regulations can restrict the age of the operator.

Keep in mind that the operator or user is responsible for accidents or hazards involving the machine that occur to other people or their property.

GENERAL SAFETY INSTRUCTIONS

It is important that you read and understand the owner's manual and labels affixed to the machine. Learn its application and limitations as well as the specific potential hazards. Retain these instructions for future reference. The operator is responsible for following the warnings & instructions in this manual and on the product.

	<p>Read & understand the operator's manual for the trolley and the ride on product used to pull the trolley before using the machine. Failure to follow instructions could result in death or serious injury.</p>		<p>Risk of Slicing. Keep hands out of the way of all moving parts.</p>
	<p>Wear gloves to protect your hands. Wear foot protection at all times.</p>		<p>Check your machine before using. Keep guards in place and in working order. Frequently check to see that foreign objects are removed before using. Replace damaged, missing or failed parts before using it.</p>
	<p>Be careful when using on slopes. Do not operate on inclines greater than 15°. It is advised to manually or with your tractor, pull up or down the incline.</p>		<p>Safety alert symbol. Used to alert you to potential personal injury hazards. Obey all safety messages that follow this symbol to avoid possible injury.</p>
	<p>Indicates an imminently hazardous situation which, if not avoided, will result in serious injury.</p>		<p>Indicates a potentially hazardous situation which, if not avoided, could result in serious injury.</p>
	<p>Indicates a potentially hazardous situation which, if not avoided, may result in minor or moderate injury.</p>	<p>CAUTION</p>	<p>Used without the safety alert symbol indicates a potentially hazardous situation which, if not avoided, may result in property damage.</p>

IMPORTANT SAFETY WARNINGS



TO REDUCE RISK OF INJURY: Before any use be sure everyone using this product reads and understands all safety instructions and other information contained in this manual.

GENERAL SAFETY

STAY ALERT

Do not operate the machine while under the influence of drugs, alcohol, or any medication that could affect your ability to use it properly. Do not use this machine when you are tired or distracted from the job at hand. Always be aware of what you are doing. Use common sense.

SMALL COMPONENTS

Contains small components that could be a choking hazard if swallowed. Keep these items away from children.

EVENLY DISTRIBUTE YOUR LOAD

Always distribute payload evenly over surface of the bed, over both axles.

USERS, BYSTANDERS AND CHILDREN

Do not at any time carry passengers in or on the trolley, stationary or whilst moving. Do not allow any person or child to play on, stand, sit, lay or climb in or on the trolley. Never allow children or people unfamiliar with

these instructions to use the trolley. Local regulations can restrict the age of the operator. Keep unauthorised persons a safe distance away from the machine. If approached, stop the machine immediately.

AVOID DANGEROUS CONDITIONS

Work in daylight or in good artificial light; walk, never run with the machine; always be sure of your footing on slopes; exercise extreme caution when changing direction on slopes; do not work on excessively steep slopes; use extreme caution when reversing or pulling the machine towards you; do not put hands or feet near or under rotating or moving parts. When operating on slopes, use up and down the incline and never across, to avoid tipping.

INSPECT YOUR MACHINE

Check all bolts, nuts, and screws for tightness before each use, especially those securing guards and drive mechanisms. Vibration during use, may cause these to loosen.

Form a habit of checking to see that all other tools/equipment are removed from the working area before operating. Replace damaged, missing or failed parts before using. Warning labels carry important information. Replace any missing or damaged warning labels.

DRESS PROPERLY

Be careful of loose clothing and other accessories (watches, necklaces etc) which can be caught in moving parts. Long trousers are advisable. Always wear substantial non slip footwear when operating. Never operate barefoot or when wearing sandals. Wear a face or dust mask if the operation is dusty. Wear protective hair covering to contain long hair, preventing it from getting caught in machinery.

DO NOT OVERREACH

Always keep proper footing and balance when using the machine. Use on slopes with great care. Never stand on the machine. Serious injury could occur if the machine is tipped or if the moving parts are unintentionally contacted. Do not store anything above or near the machine, where anyone might stand on the machine to reach them.

DO NOT FORCE TOOL

Do not exceed equipment maximum load capacity of 200kg (440lb). Avoid large holes and ditches when transporting loads. Always work within the rated capacity. Do not use machine for a purpose for which it was not intended. Be careful when operating on steep grades (hill) the trolley may tip over. Always operate at reduce speed in rough terrain, along creeks, ditches and on hillsides. Do not operate close to creeks, ditches and public highways. To avoid personal injury and/or equipment damage **DO NOT EXCEED 10 MPH**. Always use caution when loading and unloading the trolley. Only tow with recommended vehicles (Lawn/Garden Tractors and ATVs). Always secure and lock the trolley to the vehicle hitch before operating.

INSPECT

Before using, always visually inspect to see that the machine is not worn or damaged. Replace worn or damaged elements and bolts in sets, to preserve balance.

MAINTAIN YOUR MACHINE WITH CARE

Clean the machine immediately after use. Keep the machine clean to ensure it operates to its full and safest performance. When maintaining this machine, only the manufacturer's original replacement parts should be used. The use of non-original manufacturer parts may invalidate your warranty.

PROTECT THE ENVIRONMENT

Take left over materials to an authorised collection point or follow the stipulations in the country where the machine is used. Do not discharge into drains, soil or water.

STORE IDLE EQUIPMENT

When not in use, the machine should be stored in a dry location. Keep the machine away from children and others not qualified to use it. Keep away from direct sunlight.



WARNING

The warnings, cautions, and instructions outlined in this instruction manual cannot cover all possible conditions or situations that may occur. It must be understood by the operator that common sense and caution are factors which cannot be built into this product and must be supplied by the operator.

SET UP & PREPARATION FOR OPERATION

This product must be assembled correctly before use. Carefully remove the product and any accessories from the carton. Inspect the product carefully to make sure there are no breakages or missing items during shipping. Do not discard the packing material and carton until you have carefully inspected and satisfactorily operated the product.

If you require assistance with regards to the contents or operation of the machine, please contact us:

TEL: 01793 333212

EMAIL: customerservice@handydistribution.co.uk

(MON – FRI 8.00AM TO 5.00PM EXCL. BANK HOLIDAYS)



WARNING

If any parts are damaged or missing do not operate this product until the parts are replaced. Failure to heed this warning could result in serious personal injury.

Do not attempt to modify this product or create accessories not recommended for use with this product. Any such alteration or modification is misuse and could result in a hazardous condition leading to possible serious personal injury.

Read and follow all instructions for assembly and operation. Failure to properly assemble this equipment could result in serious injury to the user or bystanders, or cause equipment damage.

ASSEMBLY

All numbers mentioned in the below steps are listed in the parts list and diagram, located at the rear of this instruction manual.

STEP 1

Turn the trolley Bed (1) upside down so that the underside is facing up.

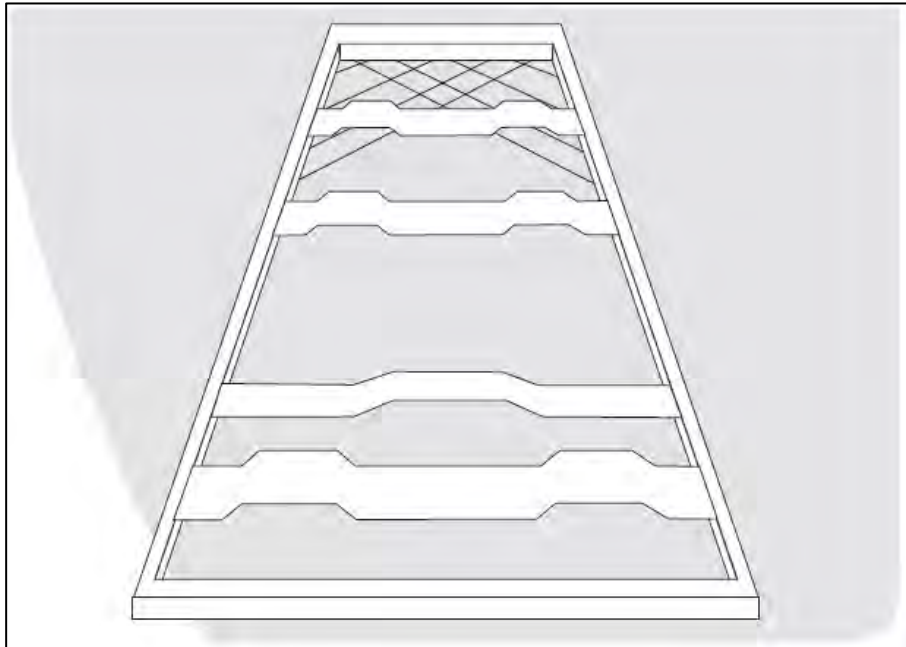

STEP 2

Attach the Rear Axle Support (6) to the Bed (1) using two Carriage Support Bolts, Washers & Nuts (18).

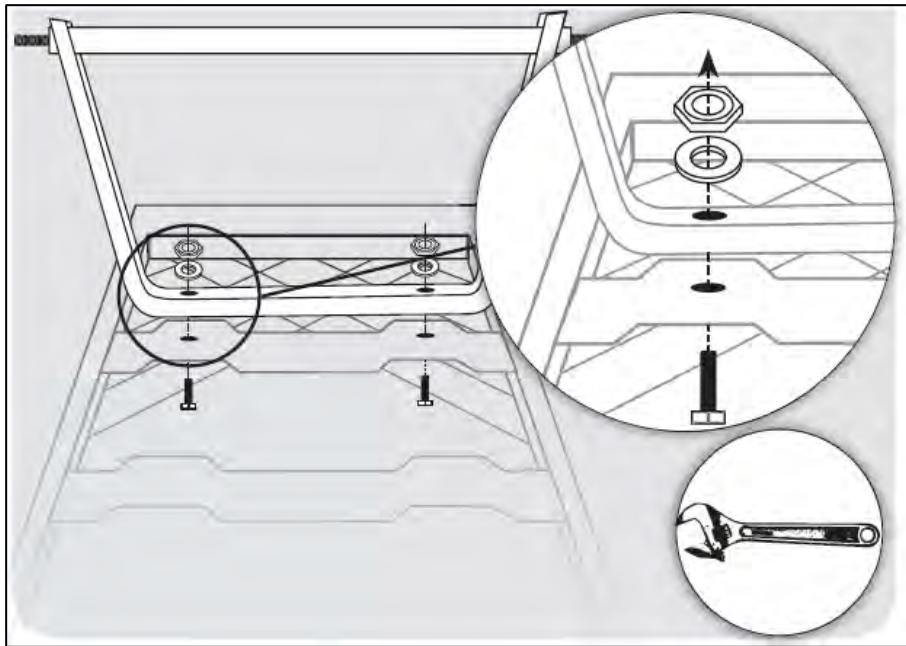

Place the Right (7) and Left (8) Rear Axle Braces onto the Rear Axle Support (6).

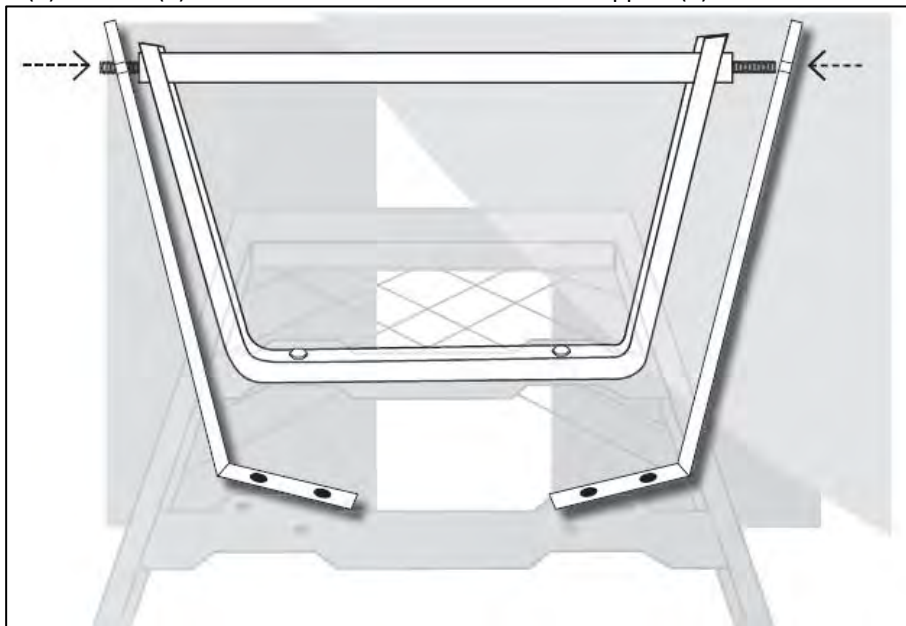

Attach the Rear Axle Braces (7 & 8) to the Bed (1) using four Carriage Support Bolts, Washers & Nuts (18).

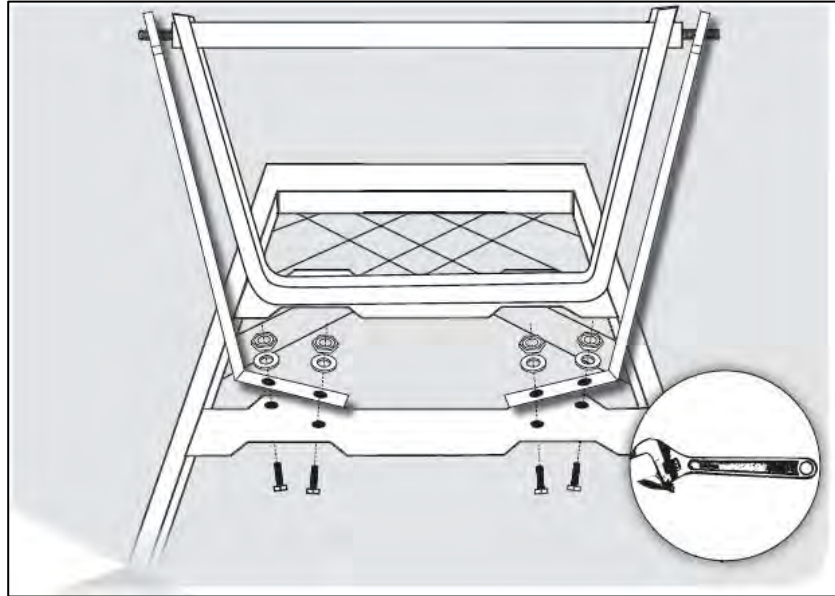

STEP 3

Attach the Front Axle Support (9) to the Bed (1) using two Carriage Support Bolts, Washers & Nuts (18).

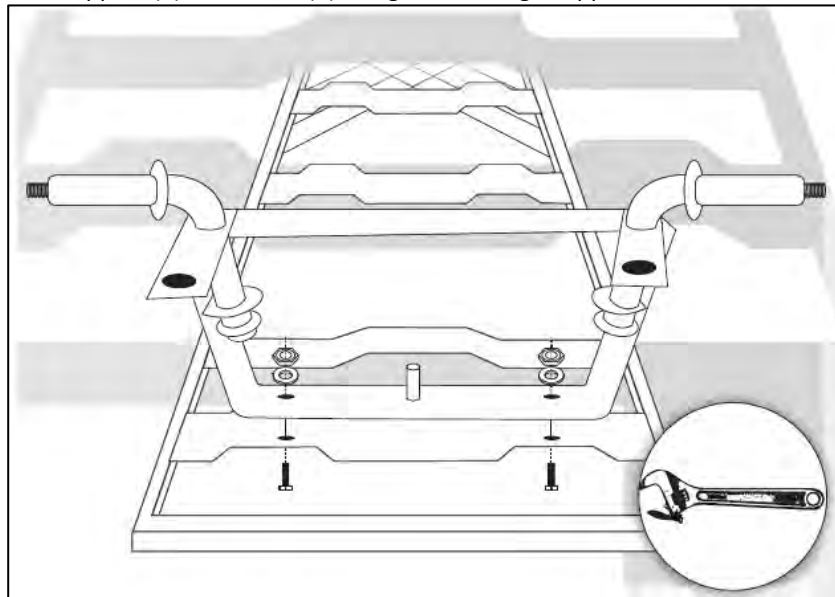

STEP 4

Attach the Steering Link Connector (12) to the Front Axle Support (9), using Bolts, Washers and Nuts (19). The connector should sit over the axle as pictured.

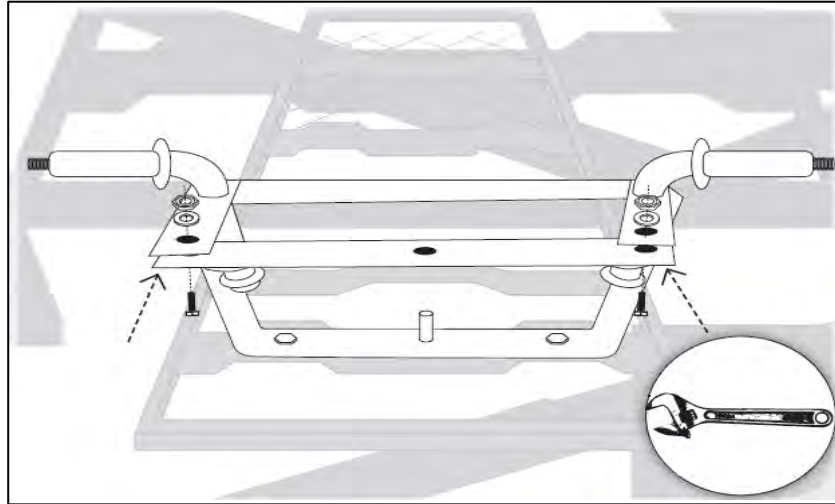

STEP 5

Position the Central Front Axle Brace (10) up to the Front Axle Support (9).

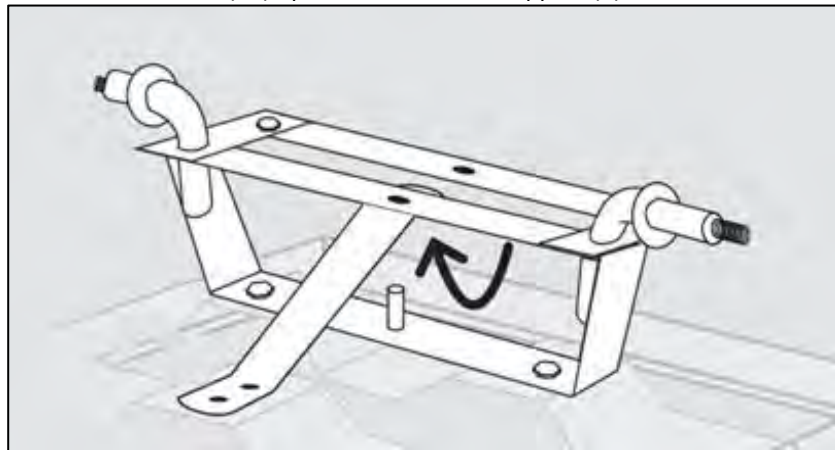

Fix the Central Front Axle Brace (10) to the Bed (1) using Carriage Bolt, Washer & Nut (18).

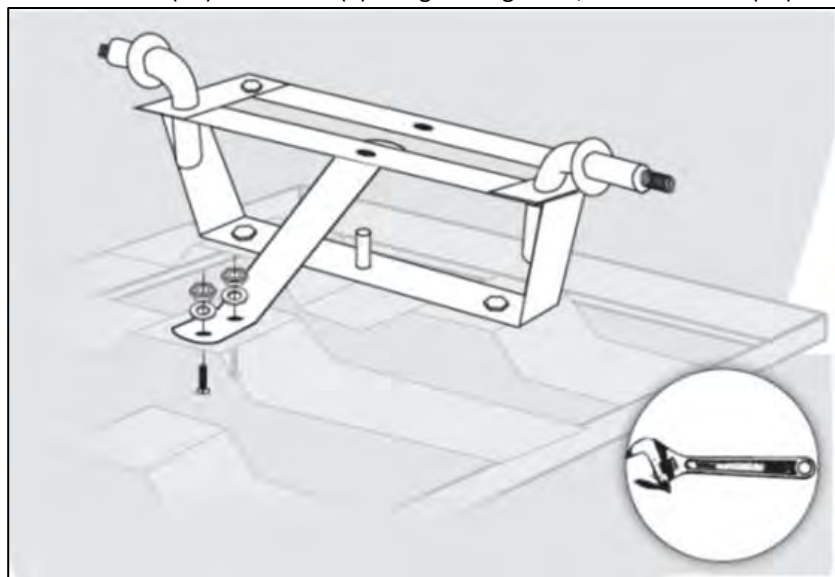

STEP 6

Slot the stepped arm of the Yoke (11) onto the protruding leg of the Front Axle Support (9) (this leg is stepped, so the Yoke (11) will not go all the way over the leg).

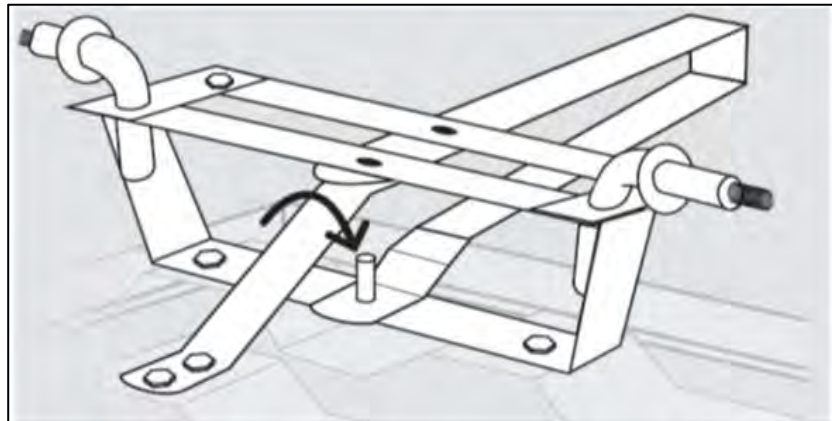

Position the straight arm of the Yoke (11) between the Centre Front Axle Brace (10) & Front Axle Support (9).

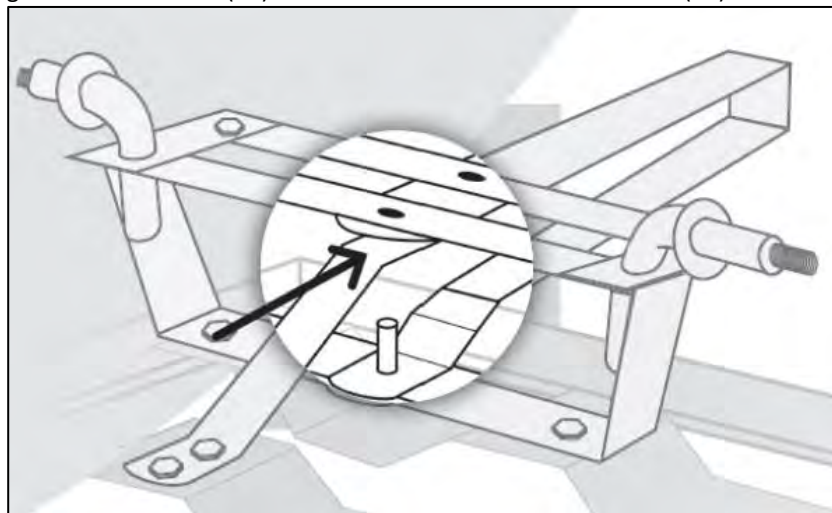

STEP 7

Fix the Yoke (11) & Centre Front Axle Brace (10) to the Front Axle Support (9) using Bolt, Washer & Nut (19).

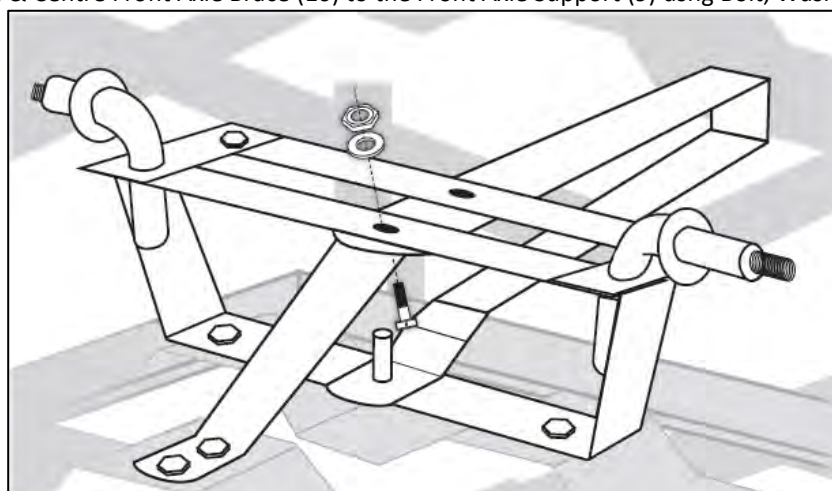

Attach the Steering Link Connector (12) to the Yoke (11) using Carriage Bolt, Washer & Nut (18).

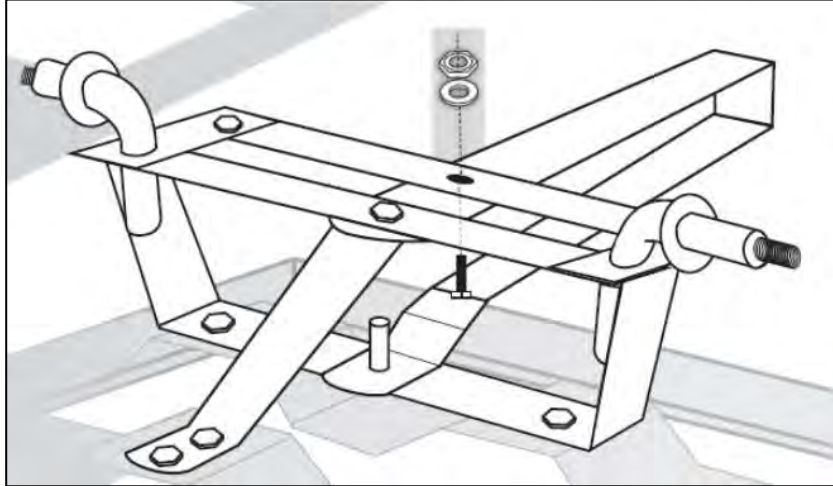

Slide the Large Washer (23) over the Front Axle Support (9) protruding leg (this is stepped) and slide the Split Pin (16) through the hole. Split open the Pin legs to secure.

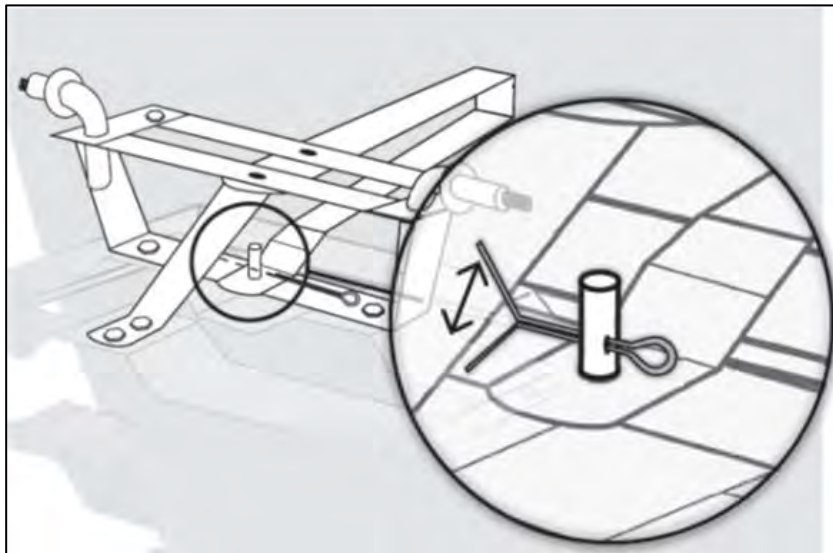

STEP 8

Attach the Pull Adapter (13) to the Yoke (11) by aligning the holes in the Lower Handle, Handle Coupling and the Yoke (11). Secure using the Pull Handle Bolt, Washer and Nut (21).

If you wish to attach the trolley to a garden tractor, remove the end of the Pull Handle by undoing the R-Clip and removing the Pull Bolt, and attach the tow hitch directly to the tractor using the same R-Clip & Pull Bolt.



STEP 9

Slide the Wheel Assembly (5) onto the axle.

Secure using a Wheel Washer (17) and a Wheel Nut (24) on to the axle. The nuts are supplied with nylon lock, which may prove difficult to tighten the nut initially.

Do not over tighten; this may cause the wheel to not rotate. Repeat with the remaining wheels.



STEP 10

Turn the Trolley over onto its wheels (DO NOT try and lift on your own, ask for assistance!)

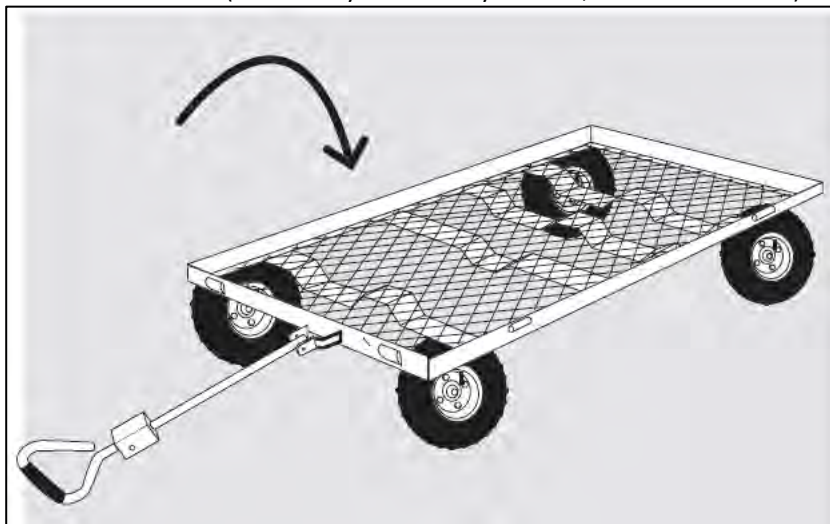

STEP 11

Attach the two Side (2), Front (3) & Rear (4) Panels to the Bed (1), using the R-Clip (20) (Two for each Panel).

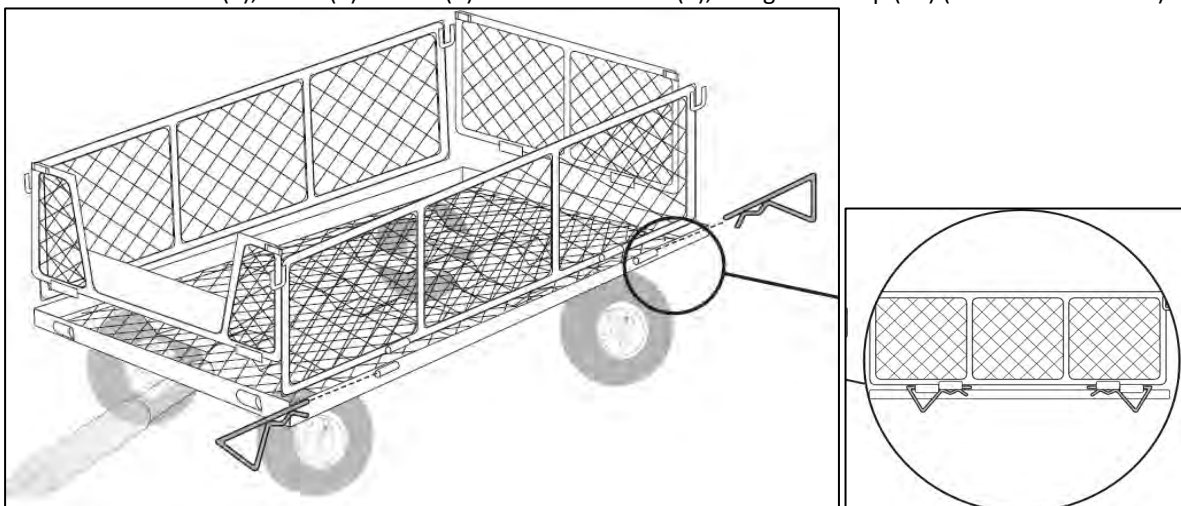

STEP 12

Position the Side Lock Handles (22) through the tabs on the top right and left of the Side (2), Front (3) & Rear (4) Panels and secure using the nut provided (do not overtighten). Ensure the threaded end faces inwards towards each other. Lift the Side (2) Panels into position and secure with the Side Lock Handle (20), by rotating. Once in position, securely tighten all nuts before use.

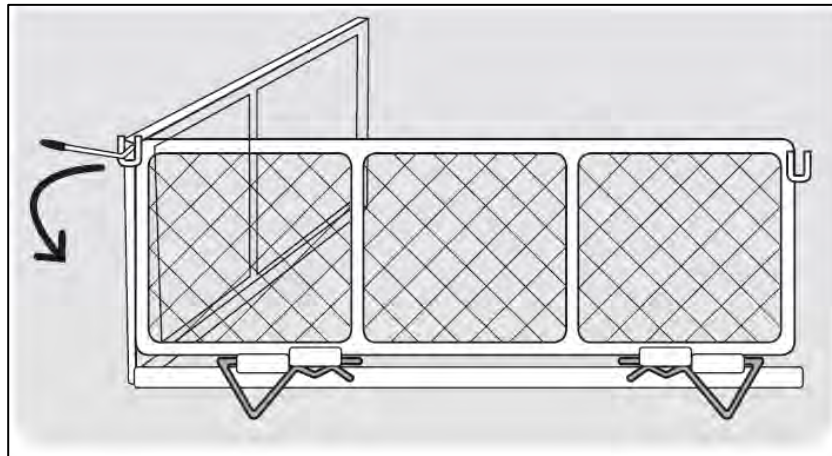

OPERATION



WARNING

Before using the trolley, review the instructions below and safety information. Failure to follow these instructions may result in property damage or injury to the operator or bystanders.

USING YOUR TROLLEY

1. **DO NOT** exceed rated load capacity of 200kg (440lb).
2. **ALWAYS** secure and lock the trolley to the ride on machinery hitch before operating.
3. **ONLY** use approved vehicles when towing the trolley (Lawn/Garden Tractors and ATVs).
4. **DO NOT** over fill the trolley. Overflow loads can cause the trolley and towing vehicle if used to lose traction and skid out of control.
5. **ALWAYS** use the trolley for its intended purpose.
6. **ALWAYS** make sure that the tow vehicle and the combined weight of the operator **MUST BE** greater than the load of the trolley weight for correct control.
7. **DO NOT** use the trolley on public highways or roads. Use of this nature can cause premature wear of the tyres, not covered by the manufacturer's warranty.
8. **NEVER** exceed 10mph when towing the trolley.
9. **DO NOT** make sharp turns that may cause the Lawn/Garden Tractor or ATV tyres to rub against the trolley.
10. **ALWAYS** slow down before turning.
11. **ALWAYS** use caution when backing the trolley. To avoid the trolley from "jack-knifing" always back up in a straight line.
12. **ENSURE** to safety instructions within this manual are **ALWAYS** adhered too.

MAINTENANCE & STORAGE



WARNING

Repairs and maintenance work other than those described within this instruction manual may be performed only by an authorised service agent.

MAINTENANCE

Users of this product should only undertake actions described in this manual, unless otherwise instructed by the manufacturer. When repairing the product, always use approved replacement Handy Parts or those which are technically identical. Using high quality replacement parts avoids the risk of accidents, damage to the product and invalidating the manufacturer's warranty.

STORAGE

Never allow carried material to remain in the Trolley for extended periods of time. For years of trouble-free service, make sure the Trolley is clean and dry before storing. Store in a dry protected area away from sunlight and severe weather in winter months. If storing for an extended period, grease the axles and wheel bearings on the Trolley.

TROUBLESHOOTING



WARNING

If the product does not perform properly, makes unusual sounds, or any other irregularity or malfunction occurs, do not attempt to repair the product by yourself. Please contact customer services or your local authorised service dealer for advice.

NEED ASSISTANCE

FOR SPARES OR SUPPORT OF YOUR HANDY PRODUCT, PLEASE CONTACT US:

TEL: 01793 333212

EMAIL: CUSTOMERSERVICE@HANDYDISTRIBUTION.CO.UK

MONDAY TO FRIDAY 8.00AM TO 5.00PM (EXCL. BANK HOLIDAYS)

PARTS DIAGRAM

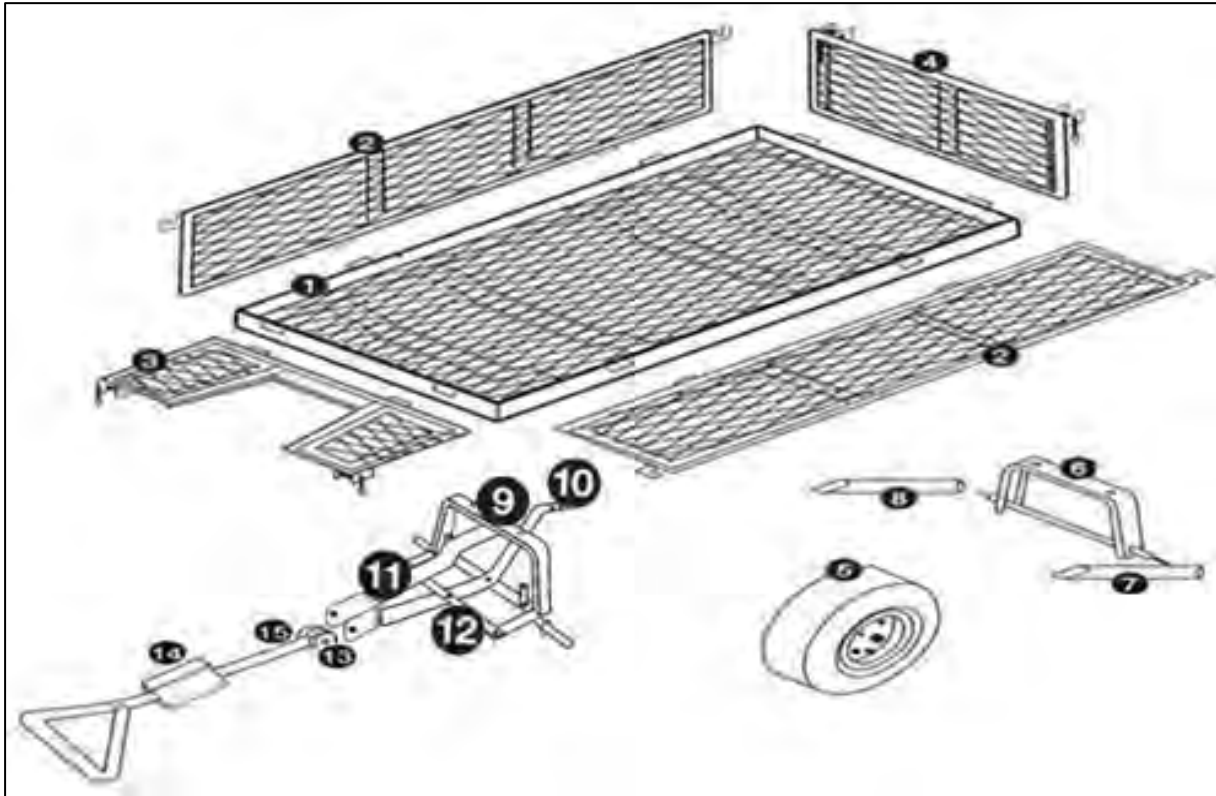





NOTE: Parts Lists are supplied for information purposes only, not all parts are stocked individually & we recommend you contact our Spares Team on 01793 333212 for expert advice.

PARTS LIST - Part 1

ITEM NO	PART NO.	DESCRIPTION	QTY
1	TH220-1-1	Bed	1
2	TH220-2-2	Side Panel	2
3	TH220-3-3	Front Panel	1
4	TH220-4-4	Rear Panel	1
5	TH219-1	Wheel Assembly	1
6	TH220-6-6	Rear Axle Support	1
7	TH220-7-7	Right Rear Axle Brace	1
8	TH220-8-8	Left Rear Axle Brace	1
9	TH220-9-9	Front Axle Support with Axles	1
10	TH220-10-10	Central Front Axle Brace	1
11	TH220-11-11	Yoke	1
12	TH220-12-12	Steering Link Connector	1
13	TH215-E2-13	Pull Adaptor	1
14	TH215-14-14	Pull Handle	1
15	TH215-15-15	Lower Pull Handle	1

PARTS LIST - Part 2

ITEM NO	PART NO	DESCRIPTION	QTY
16	TH215-A1-16	 Split Pin – 2.5x45	1
17	TH219-2	 Wheel Washer 16mm	4
18	TH215-C-18	 Carriage Support Bolt, Washer & Nut - M8x15mm	10
19	TH215-A4-19	 Bolt, Washer & Nut - M6x16mm	3
20	TH215-D-20	 R-Clip - 40x105	8
21	TH215-E1-21	 Bolt, Washer & Nut for Pull Handle - M8x60	1
22	TH215-F-22	 Panel Lever	4
23	TH215-A2-23	 Large Washer 10mm	1
24	TH215-B2-24	 M12 Wheel Lock Nut	4
25	TH215-A3-25	 Bolt, Washer & Nut - M6x20mm	1

GJ HANDY & CO LTD USER WARRANTY POLICY

VERSION 8 01-2020

Users Statement of Warranty

Each new machine is warranted against defective material or assembly of material under normal usage. The warranty applies to the original purchaser and covers faulty parts and the labour involved in replacing and repairing those parts, which are of original manufacture.

Period of Warranty

The Handy (Petrol & Electric only), Webb (excludes Dynamic, Heritage, Legacy), Sanli Engine

- a) 2 years from the original date of sale to the first domestic user.
- b) 90 days from the original date of sale to the professional/commercial user.
- c) 90 days from the original date of sale when used for hire.
- d) A reduced warranty period of 90 days applies to those items which are subject to normal wear and tear (e.g. but not limited to wheels, tyres, cutter bars, cylinders, cutting blades, blade boss, belts, cables, nylon line & spool, collection bags, spark plugs).
- e) Engines are supplied with a separate warranty to the machine. The engine manufacturers warranty statement which will be supplied within the engine instruction manual. All enquiries and warranty repairs should be discussed with the engine manufacturer or approved warranty repair dealer.
- f) 90 days from the original date of purchase for Replacement Spare Parts (unless normal wear & tear component, which are covered for 30 days).
- g) All machines' must be serviced within the first 12 months from the original date of purchase to comply with the warranty (if applicable), failure to do so will invalidate the 2nd year of the warranty.

Webb Dynamic, Heritage & Legacy, Handy (All non-Petrol & Electric), Mowerland, Q-Garden

- a) 1 year from the original date of sale to the first domestic user.
- b) 90 days from the original date of sale to the professional/commercial user.
- c) 90 days from the original date of sale when used for hire.
- d) A reduced warranty period of 90 days applies to those items which are subject to normal wear and tear (e.g. but not limited to wheels, tyres, cutter bars, cylinders, cutting blades, blade boss, belts, cables, nylon line & spool, collection bags, spark plugs).
- e) Engines are supplied with a separate warranty to the machine. The engine manufacturers warranty statement which will be supplied within the engine instruction manual. All enquiries and warranty repairs should be discussed with the engine manufacturer or approved warranty repair dealer.
- f) 90 days from the original date of purchase for Replacement Spare Parts (unless normal wear & tear component, which are covered for 30 days).

All warranty repairs must be undertaken by an authorised service dealer. These dealers have been accredited by GJ Handy & Co Ltd and agree to only use genuine parts and follow our repair procedures.

Not covered by this warranty

- a) The warranty policy does not cover any depreciation or damages caused by ordinary wear, rusting or corrosion, lack of correct maintenance or operation, misuse, abuse, lack of transportation or accident.
- b) The warranty policy does not cover any costs necessary for the standard periodic maintenance services instructed by the operator's manual, or service parts replacement which would include oil, filters, tyres, belts, brake linings, fuses, blades, seals and other service parts unless it can be proven that the item has evidence of faulty manufacture.
- c) The warranty policy will not cover failure or damage caused as a result of parts or accessories being modified without the written approval of GJ Handy & Co Ltd.
- d) The warranty policy will not cover the unit if non-genuine parts have been fitted and as a result damage has occurred to the unit.
- e) The warranty policy is non-transferable and is only applicable to the original purchaser.

Disclaimer

- a) This warranty is only a remedy for defect of products. GJ Handy & Co Ltd will never warranty in terms of the merchantability or the fitness for a particular purpose.
- b) No person is authorised to make any warranties, representations or promises, expressed or implied, on behalf of GJ Handy & Co Ltd, or to modify the terms conditions or limitation of this warranty policy in any way.
- c) Neither GJ Handy & Co Ltd nor any company affiliated with GJ Handy & Co Ltd shall be liable in any event or manner whatsoever for incidental or consequential damages or injuries, including, but not limited to, loss of crops, loss of profit, out of pocket expenses or profits, rental of substitute equipment or other commercial losses.

General

- a) Most warrantable failures show up within the first few weeks of use. These failures are usually straightforward and warranty assessment is relatively easy.
- b) Failures relating to cutter decks and belts need careful investigation, as the cause may not always be straightforward. Look for damage to blades and pulleys especially when the cutter belt or blade boss have snapped or cracked as this could be due to impact damage.
- c) Customers should always refer to the operator/instruction manual when any disputed problem arises, you will find most areas covered within the manual.

**For spares or support of your handy product,
please contact us:**

Tel: 01793 333212

**Email: customerservice@handydistribution.co.uk
(Mon – Fri 8.00am to 5.00pm excl. Bank Holidays)**

To see our range of garden machinery & equipment visit:

www.thehandy.co.uk

Making gardening easier & affordable since 1938

Distributed by Handy Distribution, Murdock Road, Dorcan, Swindon, SN3 5HY