



# INSTRUCTION MANUAL

# LIGHT CONSTRUCTION THLC29140 495MM (12") & THLC29142 530MM (14") COMPACTOR PLATE

EN - ORIGINAL INSTRUCTIONS

TWO PERSON LIFT - ASSEMBLY REQUIRED

SAVE THESE INSTRUCTIONS

SPARES & SUPPORT: 01793 333212

## FOR YOUR SAFETY

Please read & understand this manual, paying attention to the safety instructions, before use.

Incorrect use of the product could put the operator or machine in danger.

Whilst every effort has been made to ensure the accuracy of information contained in this manual, our policy of continuous improvement determines the right to make modifications without prior warning.

Images used are for illustration purposes only

THLC29140 - 1938106002

THLC29142 - 1938105002

05/07/2020

### *Copyright Notice*

Copyright © Handy Distribution

Permission is granted to reproduce this publication for personal & educational use only.

Commercial copying, redistribution, hiring or lending is prohibited.

No part of this publication may be stored in a retrieval system or transmitted in any other form or means without written permission from Handy Distribution.

In all cases this copyright notice must remain intact.

## **CONTENTS**

**INTRODUCTION**

**ENVIRONMENTAL**

**SPECIFICATION**

**GENERAL SAFETY INSTRUCTIONS**

**COMPONENTS**

**ASSEMBLY**

**KNOW YOUR MACHINE**

**OPERATION**

**SERVICE**

**MAINTENANCE**

**STORAGE**

**LIFTING & TRANSPORT**

**TROUBLE SHOOTING**

**PARTS DIAGRAM & LIST**

**WARRANTY**

**EC DECLARATION OF CONFORMITY**

### **ASSEMBLY IS REQUIRED**

This product requires assembly before use. See the "Assembly" section for instructions.

Please check that all parts required for the assembly of this machine are included. If for any reason you believe a part for the assembly is missing or damaged, please contact us.

### **ACCESSORIES**

Any reference to the Wheel (THLC31120) or Paving Pad (THLC31140 or THLC31142) kits are provided as reference points only and do not indicate that they are standard with either the THLC29140 or THLC29142. Both the Wheel and Paving Pad kits are available as accessories from your Handy supplying retailer and we recommend you discuss your needs with them, should you wish to purchase.

**If you require any assistance with regards to the contents or operation of your machine, please contact us:**

**TEL: 01793 333212**

**EMAIL: [customerservice@handydistribution.co.uk](mailto:customerservice@handydistribution.co.uk)**

**(MON – FRI 8.00AM TO 5.30PM EXCL. BANK HOLIDAYS)**

## INTRODUCTION

Your new Compactor Plate will more than satisfy your expectations. It has been manufactured under stringent quality standards to meet superior performance criteria. You will find it easy and safe to operate and with proper care, it will give you many years of dependable service.



**Carefully read through this entire instruction manual before using your new unit. Take special care to adhere to the cautions and warnings**

Our commitment to quality can be seen in the design and features of our machine: reinforced self-cleaning base plate, engine oil drain hose, closed V-belt guard, self-adjusting centrifugal clutch and a folding handle. A range of useful accessories enables use in all kinds of applications.

The Compactor Plate applies energy to the loose soil or other materials to increase its density and load bearing capacity, mainly used for small repair and maintenance work. The loose soil or particles are compressed. This removes trapped air and gaps in the soil. It increases the load bearing capacity, decreases water seepage, prevents soil settlement, reduces swelling, contraction of the soil and prevents frost damage. It is ideal for compaction of granular soils, sands, gravel, crushed aggregate and mixed soils.



**This compactor is not intended to be used on cohesive soils, such as clay or hard surfaces like concrete.**

## ENVIROMENTAL



Recycle unwanted materials instead of disposing of them as waste. All tools, hoses and packaging should be sorted, taken to the local recycling center and disposed of in an environmentally safe way

## SPECIFICATION















**The manufacturer reserves the right to change the product specification and livery according to continued product improvements.**

| Model             | THLC29140                 | THLC29142                 |
|-------------------|---------------------------|---------------------------|
| Product Number    | 1938106002                | 1938105002                |
| Engine            | Loncin LC152F 79cc Euro V | Loncin G200F 196cc Euro V |
| Plate Size        | 495 x 320mm               | 530 x 370mm               |
| Rated Speed       | 3600/min                  |                           |
| Exciter Speed     | 5900vpm                   | 5500vpm                   |
| Compaction        | 20cm                      | 25cm                      |
| Travel Speed      | 25m/min                   |                           |
| Product Weight    | 53kg                      | 63kg                      |
| Sound Power Level | 103 dB(A)                 | 105 dB(A)                 |

## GENERAL SAFETY INSTRUCTIONS

Read and understand the owner's manual and labels affixed to the machine. Learn its application and limitations as well as the specific potential hazards. Retain these instructions for future reference. The operator is responsible for following the warnings & instructions in this manual and on the product.

**WARNING! Failure to comply with these instructions may result in damage to the machine or other property and/or personal injury.**

|   |  |   |  |
|---|--|---|--|
|                      | <p>Read &amp; understand this manual before using the machine.</p>   |                      | <p>Wear safety gloves.<br/>Always Wear ear &amp; eye protection.<br/>Safety footwear, gloves and helmet</p>  |
|                      | <p>Hot surfaces.<br/>Contact may cause physical damage.</p>  |                      | <p>Do not remove protection or safety devices.</p>   |
|                      | <p>Fire Risk<br/>Fire and its vapors are extremely flammable &amp; explosive.<br/>Fire or explosion can cause severe burns or death.</p>   |                      | <p>Acoustic power level <math>L_{WA}</math> accordance with directive 2000/14/EC + 2005/88/EC<br/>(Please see machine &amp; specification within this manual for actual reading)</p> |
|                    | <p>Do not smoke or have open flames when operating.<br/>Use extreme caution when storing, handling and using fuels, as they are highly volatile and explosive in a vapour state.</p> |                    | <p>Keep bystanders, children &amp; pets a minimum of 20 metres away from the machine. If they approach, stop the machine immediately.</p>  |
|                    | <p>Keep hands and feet away from tracks and rotating parts.</p>  |                    | <p>Caution: Thrown objects.</p>  |
|                    | <p>Safety Alert Symbol. Used to alert you to potential personal injury hazards. Obey all safety messages that follow this symbol to avoid possible injury.</p>                       | <br><b>DANGER</b>  | <p>Indicates an imminently hazardous situation which, if not avoided, will result in serious injury.</p>   |
| <br><b>WARNING</b> | <p>Indicates a potentially hazardous situation which, if not avoided, could result in serious injury</p>   | <br><b>CAUTION</b> | <p>Indicates a potentially hazardous situation which, if not avoided, may result in minor or moderate injury.</p>  |
| <b>CAUTION</b>  | <p>Used without the safety alert symbol indicates a potentially hazardous situation which, if not avoided, may result in property damage.</p>  |   |  |

# UNDERSTAND YOUR MACHINE

## GENERAL SAFETY RULES

- Read and understand the operator's manual and labels affixed to the machine. Learn its application and limitations as well as the specific potential hazards peculiar to it.
- Be thoroughly familiar with the controls and the correct operation. Know how to stop the machine and disengage the controls quickly.
- **Make sure you read and understand all the instructions and safety precautions as outlined in the Loncin Engine Manual, packed separately with your unit. Do not attempt to operate the machine until you fully understand how to properly operate and maintain the Engine and how to avoid accidental injuries and/or property damage.**

## WORK AREA

- Never start or run the engine inside a closed area.
- Exhaust fumes are dangerous, containing carbon monoxide, an odourless and deadly gas. Operate this unit only in a well-ventilated outdoor area.
- Never operate the machine without good visibility or light.

## PERSONAL SAFETY

- Do not operate the machine while under the influence of drugs, alcohol, or any medication that could affect your ability to use it properly.
- Dress sensibly. Wear heavy trousers, boots and gloves. Do not wear loose clothing, shorts, jewellery of any kind. Secure long hair so it is above shoulder level. Keep your hair, clothing and gloves away from moving parts. Loose clothes, jewellery or long hair can be caught in moving parts.
- Check your machine before starting it. Keep guards in place and in working order. Make sure all nuts, bolts, etc. are securely tightened.
- Never operate the machine when it needs repair or is in poor mechanical condition. Replace damaged, missing or failed parts before using it.
- Check for fuel leaks. Keep the machine in safe working condition.
- Do not use the machine if the engine's switch does not turn it on or off. Any petrol-powered machine that cannot be controlled with the engine switch is dangerous and it must be repaired or replaced.
- Before every use, check to see that keys and adjusting wrenches are removed from the machine area before starting it. A wrench or a key that is left attached to a rotating part of the machine may result in personal injury.
- Stay alert, watch what you are doing and use common sense when operating the machine.
- Do not overreach. Do not operate the machine while barefoot or when wearing sandals or similar lightweight footwear. Wear protective footwear that will protect your feet and improve your footing on slippery surfaces. Always keep proper footing and balance. This enables better control of the machine in unexpected situations.
- Avoid accidental starting. Be sure the engine's switch is off before transporting the machine or performing any maintenance or service on the unit. Transporting or performing maintenance or service on a machine with its switch on, invites accidents.

## FUEL SAFETY

- Fuel is highly flammable, and its vapours can explode if ignited. Take precautions when using to reduce the chance of serious personal injury.
- Only refill or drain the fuel tank in a clean, well-ventilated outdoor area. Use an approved fuel storage container. Do not smoke, or allow sparks, open flames or other sources of ignition near the area while adding fuel or operating the unit. Never fill the fuel tank indoors.
- Keep grounded conductive objects, such as tools, away from exposed, live electrical parts and connections to avoid sparking or arcing, which could ignite fumes or vapours.
- Always stop the engine and allow it to cool before filling the fuel tank. Never remove the cap of the fuel tank or add fuel while the engine is running or when the engine is hot. Do not operate the machine with known leaks in the fuel system.
- Loosen the fuel tank cap slowly to relieve any pressure in the tank.
- Never overfill the fuel tank (there should be no fuel above the upper limit mark).
- Replace all fuel tank and container caps securely and wipe up spilled fuel. Never operate the unit without the fuel cap securely in place.
- Avoid creating a source of ignition for spilled fuel.

- If fuel is spilled, do not attempt to start the engine but move the machine away from the area of spillage and avoid creating any source of ignition until fuel vapours have dissipated.
- Store fuel in containers specifically designed and approved for this purpose.
- Store fuel in a cool, well-ventilated area, safely away from sparks, open flames or other sources of ignition.
- Never store fuel or a machine with fuel in the tank inside a building where fumes may reach a spark, open flame, or any other source of ignition, such as a water heater, furnace, clothes dryer or similar. Allow the engine to cool before storing in any enclosure.

#### **MACHINE USE AND CARE**

- Never pick up or carry a machine while the engine is running.
- Do not force the machine. Use the correct machine for your application. The correct machine will do the job better and safer at the rate for which it was designed.
- Do not change the engine governor settings or over-speed the engine. The governor controls the maximum safe operating speed of the engine.
- Do not run the engine at a high speed when you are not working.
- Do not put hands or feet near rotating parts.
- Avoid contact with hot fuel, oil, exhaust fumes and hot surfaces. Do not touch the engine or muffler. These parts get extremely hot during use. They remain hot for a short time after you turn off the unit. Allow the engine to cool before performing maintenance or make adjustments.
- If the machine starts to make an unusual noise or vibration, immediately shut off the engine, disconnect the spark plug wire, and check for the cause. An unusual noise or vibration is generally a warning of an issue with the machine.
- Use only accessories approved by the manufacturer. Failure to do so can result in personal injury.
- Maintain the machine. Check for misalignment or binding of moving parts, breakage of parts and any other condition that may affect the machine's operation. If damaged, have the machine repaired before use. Many accidents are caused by poorly maintained equipment.
- Keep the engine and muffler free of grass, leaves, excessive grease or carbon build up to reduce the chance of a fire hazard.
- Never douse or squirt the unit with water or any other liquid. Keep handles dry, clean and free from debris. Clean after each use.
- Observe proper disposal laws and regulations for gas, oil, etc. to protect the environment.
- Don't store the machine where children will be able to access it. Don't allow persons unfamiliar with the machine or these instructions to operate it. The machine is dangerous in the hands of untrained users.

#### **SERVICE**

- Before cleaning, repair, inspecting, or adjusting, shut off the engine and make certain all moving parts have stopped. Always make sure the engine's switch is in its "OFF" position. Disconnect the spark plug wire and keep the wire away from the plug to prevent accidental starting.
- Have your machine serviced by qualified repair personnel using only approved replacement parts. This will ensure that the machine remains safe to use.

#### **SPECIFIC SAFETY RULES**

- To avoid injury, keep hands, fingers and feet away from the base plate. Grip the handle of the plate compactor firmly with both hands. If both hands are holding the handle and your feet are clear of the compactor base, your hands, fingers and feet cannot be injured by the compactor base.
- Always operate the machine from behind, never pass or stand in front of the machine when the engine is running.
- Never place tools or any other items under the plate compactor.
- If the unit strikes a foreign object, stop the engine, disconnect the spark plug, thoroughly inspect the machine for any damage and repair the damage before restarting and operating the machine.
- Do not overload the machine capacity by compacting too deep in a single pass or at too fast a rate.
- Never operate the unit at high transport speeds on hard or slippery surfaces.
- Exercise extreme caution when operating on or crossing gravel drives, walks, or roads. Stay alert for hidden hazards or traffic. Do not carry passengers.
- Never leave the operating position while working or leave the plate compactor unattended when the engine is running.
- Always stop the engine when you stop working or when walking from one location to another.
- Stay away from the edges of ditches and be careful not to cause the plate compactor to topple over.

- Always ascend slopes carefully, in a direct path and in reverse to prevent the plate compactor from toppling over onto the operator.
- Always park the unit on a firm and level surface and shut the tool off.
- To reduce exposure to vibration, limit the hours of operation and take periodic breaks to minimize repetition and rest your hands. Reduce the speed and force in which you do the repetitive movement.
- Try to vary the jobs you do each day so that you are not frequently using hand-held power equipment.

#### PROTECT THE ENVIRONMENT

- Recycle unwanted materials to an authorised collection point or follow the stipulations in the country where the machine is used. Do not discharge into drains, soil or water.

#### ENGINE MANUFACTURER

- The Engine manufacturer is responsible for all engine-related issues with regards to performance, power rating, specifications, warranty and service. Please refer to the Engine Manufacturer's owner's/operator's manual, packed separately with your unit, for more information.

## COMPONENTS

The machine is supplied partially assembled from the Distributor. Ensure all the components are included in your package.

If you believe you are missing or have received defective parts, please contact:

**Email: [customerservice@handydistribution.co.uk](mailto:customerservice@handydistribution.co.uk)**

**Telephone: 01793 333212**

**(Monday to Friday – 8.00am to 5.30pm excl. Bank Holidays).**

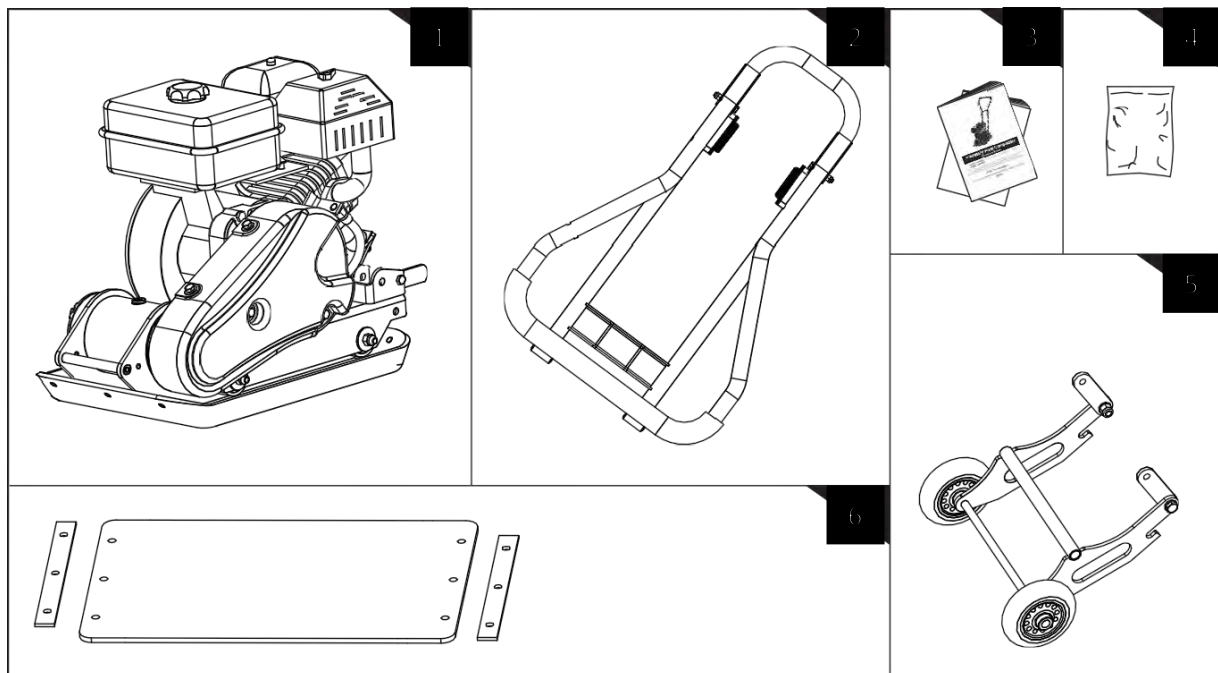

1. Compactor Plate with Engine & Transmission
2. Handle Assembly
3. Machine Instruction Manual x1 – Loncin Engine Manual x1
4. Hardware Pack (incl. M5x25 Bolt x1, M10x65 Bolt, Washer & Nut x2)
5. Folding Transport Wheel Kit (**THLC31120 - Optional Extra, not standard**)
6. Paving Pad Kit (**THLC31140 or THLC31142 - Optional Extra, not standard**)



## ASSEMBLY

Follow the below assembly instructions carefully, you should be able to assemble the machine in a short period.

### STEP 1

Unfold the handle assembly as shown.

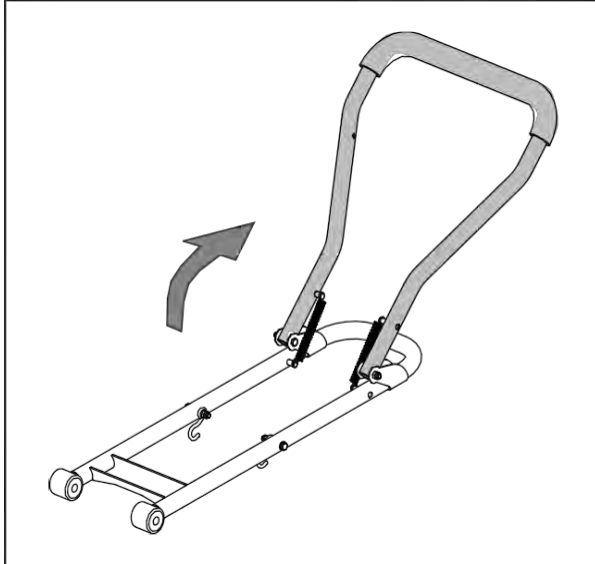

### STEP 2

- Mount the Handle as shown. Slot the Handle Ends into the channels provided by the Engine Deck. Place flat washers M10, followed by hex bolts M10x65 at the outer side, and tighten with lock nuts M10 at the inner side.
- Secure the Throttle Control onto the Upper Handle with a flat washer M5 and a bolt 5x25.
- Fasten the Throttle Control cable with cable fasteners.

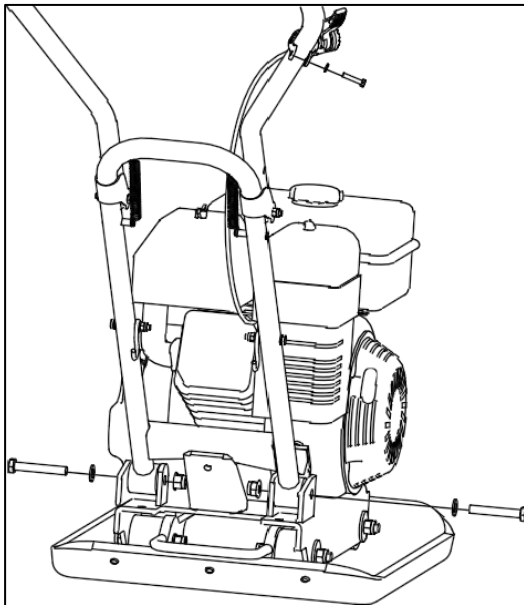

### STEP 3

#### FOLDING WHEEL KIT (NOT STANDARD - AVAILABLE AS AN ACCESSORY)

Line up the holes in the Link Plates and Engine Deck. Slide Bolts M10x30 through the holes from one side, then lock nuts M10 from the other side. (Fixings Supplied with optional kit) Tighten them down.

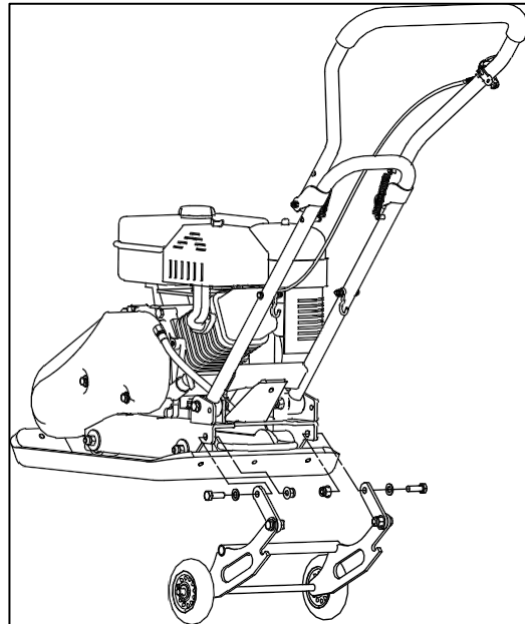

Before compacting, fold up the wheel kit.

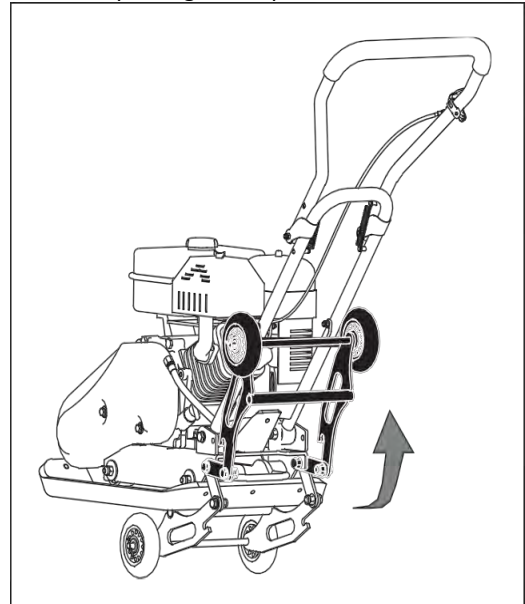

**STEP 4**

**PAVING PAD KIT (NOT STANDARD - AVAILABLE AS AN ACCESSORY)**

The transparent rubber Paving Pad allows you to compact concrete paving slabs, stones, bricks and blocks quietly and gently.

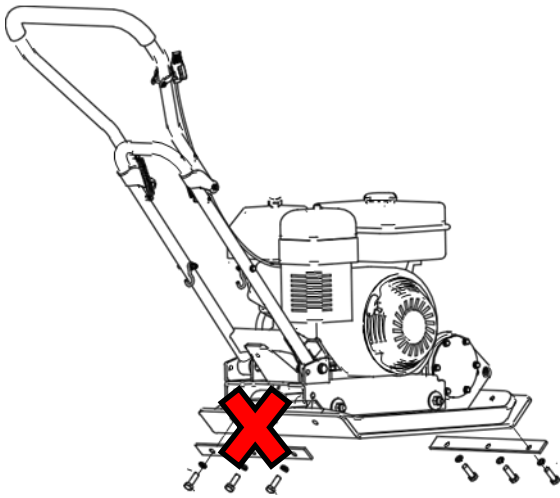

Attach the Paving Pad onto the front of the Base Plate as shown (DO NOT ATTACH TO THE REAR). Align the holes in the Base Plate, Paving Pad and Clamp Plates, and secure it with lock washers 10 and bolts M10x30.

## KNOW YOUR MACHINE

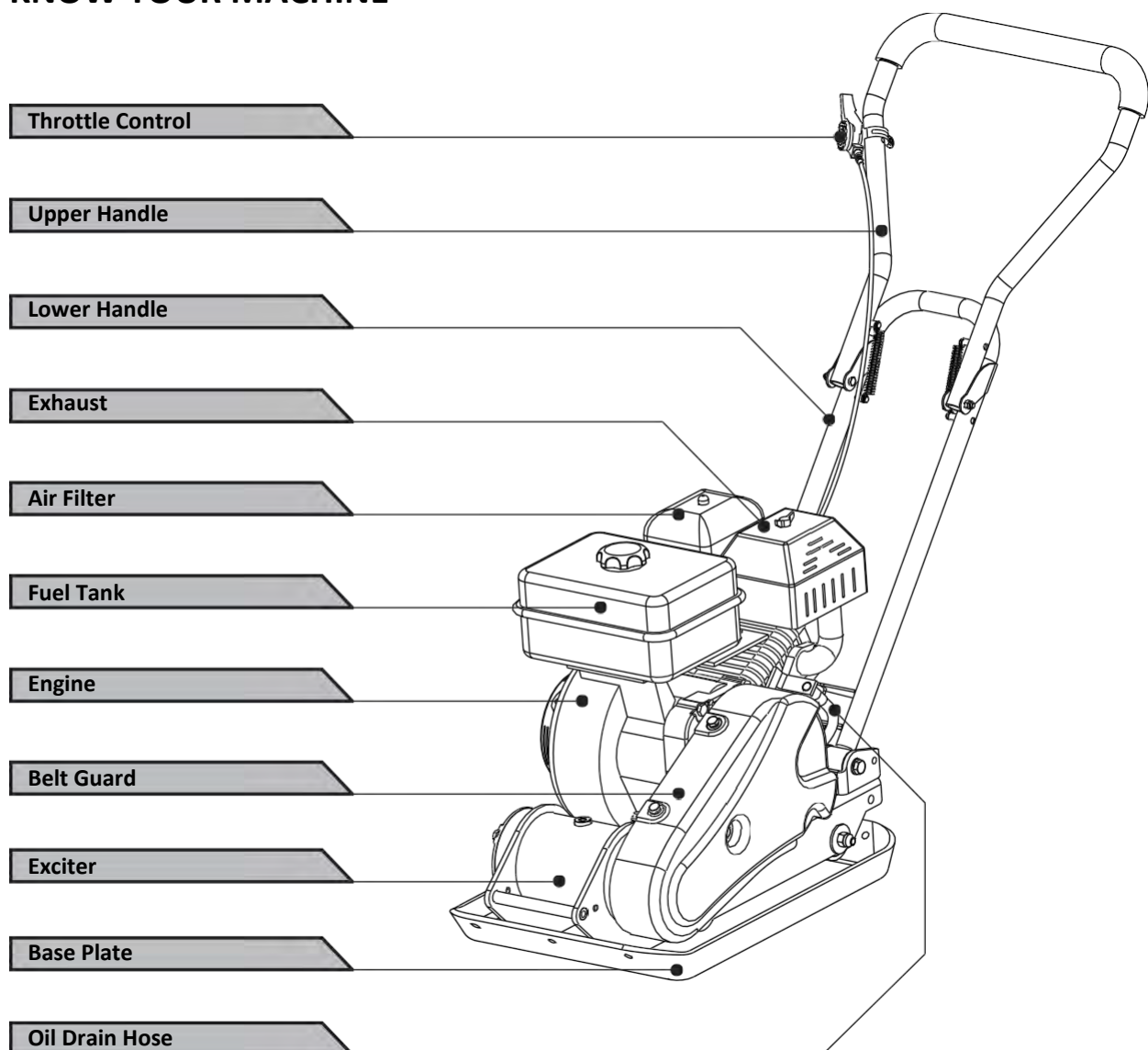

### FUEL VALVE CONTROL

The fuel valve opens and closes the passage between the fuel tank and the carburettor. The fuel valve lever must be in the ON position for the engine to run. When the engine is not in use, leave the fuel valve lever in the OFF position to prevent the carburettor flooding and to reduce the possibility of fuel leakage.

### THROTTLE CONTROL

The throttle lever controls engine speed. Moving the throttle lever makes the engine run faster or slower.

### ENGINE SWITCH

The engine switch enables and disables the ignition system. The engine switch must be in the ON position for the engine to run. Turning the engine switch to the OFF position stops the engine.

### CHOKE LEVER

The choke lever opens and closes the choke valve in the carburettor. The closed position enriches the fuel mixture for starting a cold engine. The open position provides the correct fuel mixture for operation after starting, and for restarting a warm engine. Some engine applications use a remotely-mounted choke control rather than the engine-mounted choke lever.

### RECOIL STARTER GRIP

Pulling the starter grip operates the recoil starter to crank the engine.

### OIL DRAIN HOSE

Running the engine with dirty oil can cause premature engine wear and failure. Changing oil regularly is extremely important. The flexible oil drain hose is equipped to drain oil into the appropriate receptacle.

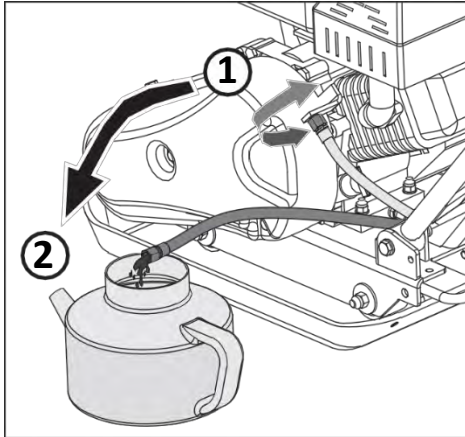

### EXCITER

An eccentric weight mounted on the exciter shaft contained within the exciter housing is driven at high speed by a clutch and belt drive system. This high-speed shaft revolution causes the rapid lifting and downward ramming motion of the machine as well as imparting a forward motion.

### FUEL SAFETY

- Fuel is highly flammable, and its vapours can explode if ignited. Take precautions when using to reduce the chance of serious personal injury.
- Only refill or drain the fuel tank in a clean well-ventilated outdoor area. Use an approved fuel storage container. Do not smoke, or allow sparks, open flames or other sources of ignition near the area while adding fuel or operating the unit. Never fill the fuel tank indoors.
- Keep grounded conductive objects, such as tools, away from exposed, live electrical parts and connections to avoid sparking or arcing. These events could ignite fumes or vapours.
- Always stop the engine and allow it to cool before filling the fuel tank. Never remove the cap of the fuel tank or add fuel while the engine is running or when the engine is hot. Do not operate the machine with known leaks in the fuel system.
- Loosen the fuel tank cap slowly to relieve any pressure in the tank.
- Replace all fuel tank and container caps securely and wipe up spilled fuel. Never operate the unit without the fuel cap securely in place.
- Avoid creating a source of ignition for spilled fuel. If fuel is spilled, do not attempt to start the engine but move the machine away from the area of spillage and avoid creating any source of ignition until fuel vapours have dissipated.
- Store fuel in containers specifically designed and approved for this purpose, safely away from sparks, open flames or other ignition sources.
- Never store a machine with fuel in the tank, inside a building where fumes may reach a spark, open flame, or other ignition source. Store fuel in a cool, well-ventilated area.
- Allow the engine to cool before storing in any enclosure.



### ADDING FUEL

Fill the fuel tank as instructed in the separate Engine Manual packed with the machine.

Fill the tank to no more than 12.5mm (1/2") below the bottom of the filler neck to allow space for expansion.

## OPERATION

### CAUTION

Engine Oil has been drained for shipping. Failure to fill the engine sump with oil before starting the engine will result in permanent damage and will void the engine manufacturers warranty.

**ADD OIL ACCORDING TO THE ENGINE MANUFACTURERS ENGINE MANUAL, PACKED SEPERATELY WITH YOUR MACHINE.**

- Never position the machine in a place with unstable ground.
- Start the engine carefully according to the engine instruction manual, with your feet well away from the moving parts.
- Never leave the operating position when the engine is running.
- Always hold the unit with both hands when operating. Keep a firm grip on the handlebars. Be aware that the machine may unexpectedly bounce upward or jump forward if the machine strikes buried obstacles such as large stones.
- Walk, never run with the machine.
- Use extreme caution when pulling the machine towards you.
- Exercise extreme caution when operating on or crossing gravel drives, walks, or roads. Stay alert for hidden hazards or traffic.
- On soft ground, do not rapidly accelerate, turn sharply or stop.
- Pay the utmost attention when working on frozen ground, the machine may tend to skid.
- Do not operate the machine in confined areas where there may be a risk of crushing the operator between the machine and another object.
- Never operate the machine on slopes where the angle is over 20° degrees.
- When moving over a slope, whether moving forward or in reverse, always make certain that the weight is evenly balanced. Always move in directions parallel with the slope.

### STARTING THE ENGINE



**DO NOT START THE MACHINE WITHOUT CONSULTING THE LONCIN ENGINE MANUAL SUPPLIED WITH YOUR MACHINE**

A more detailed description of the engine operation and all related precautions and procedures can be found in the Engine Manual packed separately with the machine. If the Engine Manual has not been supplied with your machine, contact us or visit [www.thehandy.co.uk](http://www.thehandy.co.uk).

## USING THE MACHINE



**Do not operate the plate on concrete or on extremely hard, dry, compacted surfaces. The plate will jump rather than vibrate and could damage both the plate and engine.**

- After the engine warms up, pull throttle lever to accelerate the engine speed. The plate will begin vibrating and move forward.
- The plate compactor is designed to run at an engine speed (engine take off shaft) of 3600 rpm (normally considered full throttle). Running the engine at lower rpms will result in a decrease of compaction force and lower travel speed. It will create excessive “out-of-synch” vibrations resulting in poor compaction, movement, excessive wear to the machine, and discomfort to the operator.
- In operation, guide the machine, but let the compactor do the work. Bearing down on the handle is unnecessary and causes shock absorber wear.
- On level surfaces the compactor moves forward rapidly. On uneven surfaces or inclines, light forward pressure on the handle may be required to assist the compactor in moving forward.
- The number of passes required to reach a desired compaction level will depend on the type and moisture content of soil. Maximum soil compaction has been reached when excessive kickback is noticed.

### ADVICE

***When using the plate on paving stones, attach a pad to the bottom of the plate to prevent chipping or grinding the surface of the stones. A special urethane pad designed for this purpose is available as an optional accessory (THLC31140 30cm 12” or THLC31142 35cm 14”).***

***While a certain amount of moisture in the soil is necessary, excessive moisture may cause soil particles to stick together and prevent good compaction. If soil is extremely wet, allow it to dry somewhat before compacting.***

***If soil is so dry as to create dust clouds while operating the plate, some moisture should be added to the ground material to improve compacting. This will also reduce service to the air filter.***

## STOPPING THE ENGINE

To stop the engine in an emergency, simply turn the engine switch to the OFF position. Under normal conditions, use the following procedure.

- Move the throttle lever to the SLOW position.
- Let engine idle for one or two minutes.
- Turn the engine switch to the OFF position
- Turn the fuel valve lever to the OFF position.



**DO NOT MOVE THE CHOKE LEVER TO 'CHOKE' TO STOP THE ENGINE. BACKFIRE OR ENGINE DAMAGE MAY OCCUR. ANY DAMAGE WILL NOT BE COVERED BY WARRANTY. FULL DETAILS ARE AVAILABLE IN THE ENGINE MANUAL.**

## IDLE SPEED

Set the throttle control lever to its "low" position to reduce stress on the engine when compacting is not being performed. Lowering the engine speed to idle the engine will help extend the life of the engine, as well as conserve fuel and reduce the noise level of the machine.

## SERVICE

Before cleaning, repairing, inspecting, or adjusting, shut off the engine and make certain all moving parts have stopped. Disconnect the spark plug wire and keep the wire away from the plug to prevent accidental starting. Have your machine serviced by an approved service dealer using only identical replacement parts. This will ensure that the machine remains safe to use.

## MAINTENANCE

Maintaining your compactor will ensure long life to the machine and its components.

## PREVENTIVE MAINTENANCE

- Turn off the engine. it must be cool.
- Keep the engine's throttle lever in its SLOW position, and remove the spark plug wire from the spark plug and secure.
- Inspect the condition of the compactor. Check for loose screws, misalignment or binding of moving parts, cracked or broken parts, & any other condition that may affect its safe operation.
- Remove all debris from the plate compactor with a soft brush, vacuum, or compressed air. Then use a premium quality lightweight machine oil to lubricate all moving parts.
- Clean the bottom of the compactor base, as soon as it begins to pick up debris. The unit cannot operate correctly if the surface is not smooth & clean.
- Replace the spark plug wire.



**Never use a pressure washer to the machine. Water can penetrate tight areas of the unit and cause damage to spindles, pulleys, bearings or the engine.**

**The use of pressure washers will result in shortened life and reduce serviceability of the machine.**

## CHECKING V-BELT(S)

To ensure optimum power transmission from the engine to the eccentric shaft, the V-belt(s) must be in good condition & operate under proper tension.

- Turn off the engine. The engine must be cool.
- Remove the belt guard to access the V-belt(s).
- Check the condition of the V-belt(s). If a V-belt is cracked, frayed, or glazed, it should be replaced as soon as possible.
- Check the V-belt tension by squeezing them in the centre. The normal deflection on each side should be 9mm (3/8") to 13mm (1/2") with moderate pressure from your thumb or finger.

## IMPORTANT

***On new machines or after installing a new belt, check the belt tension after the first 20 hours of operation. Check and adjust the belt every 50 hours thereafter.***

## TENSION V-BELT(S)

Proper belt tension is critical to good performance. Proper adjustment will ensure long belt life. Too much or too little belt tension will cause premature belt failure.

- Loosen the 4 engine mount bolts (do not remove) only enough to move the engine forward.

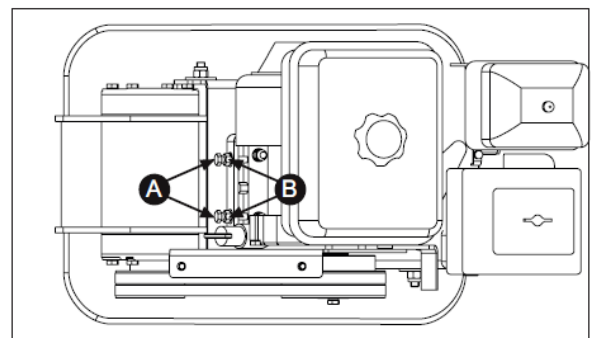

- Loosen the jam nuts B, leaving enough space between the nut and bracket
- Push the engine toward the back of the plate by turning the adjustment bolts A to remove any slack in the V-belt(s).

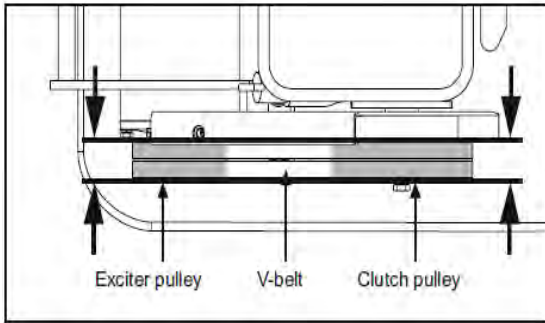

**When adjusting the belt(s), make sure that the clutch pulley is in alignment with the exciter pulley.**

- When the V-belt tension is correct, tighten the jam nuts (B) against the bracket.
- Tighten the engine mount bolts.
- Replace the belt guard.

***If the adjustment bolts cannot be adjusted any further, the belt(s) may have to be replaced.***

#### REPLACING V-BELT(S)

***For THLC29142, both V-Belts should be replaced at the same time because they will wear evenly through normal use. Work on one belt at a time.***

- Loosen the 4 engine mount bolts (do not remove) only enough to move the engine forward.
- Loosen the jam nuts (B) and bolts (A) shown in the above figure.
- Slide the engine toward the front of the plate and slip the old V-belt(s) off the wheel pulley and install the new V-belt(s) in their place.
- Position the V-belt(s) over the engine pulley.
- Move the engine back.

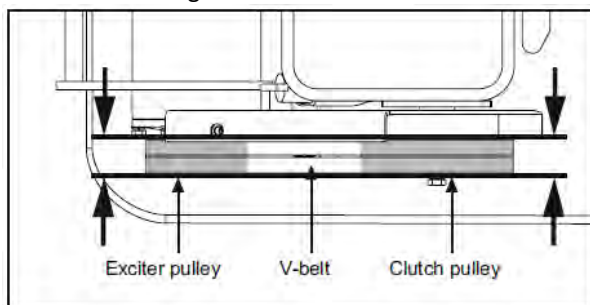

**When adjusting the belt(s), make sure that the clutch pulley is in alignment with the exciter pulley.**

- When the V-belt tension is correct, tighten the nuts & the engine mount bolts.
- Replace the belt guard.



**When removing, or installing the drive belt(s), be careful not to get your fingers caught between the belt and the pulley.**

#### EXCITER LUBRICATION

The exciter housing is pre-serviced using Automatic Transmission Fluid Dextron III, Mercon, EXXON (ESSO) NUTO H-32 or its equivalent. Change fluid after 200 hours of operation. Let the exciter cool before changing the exciter oil.

- Remove the belt guard and V-belt(s).
- Remove the bolts that hold the deck to the housing.

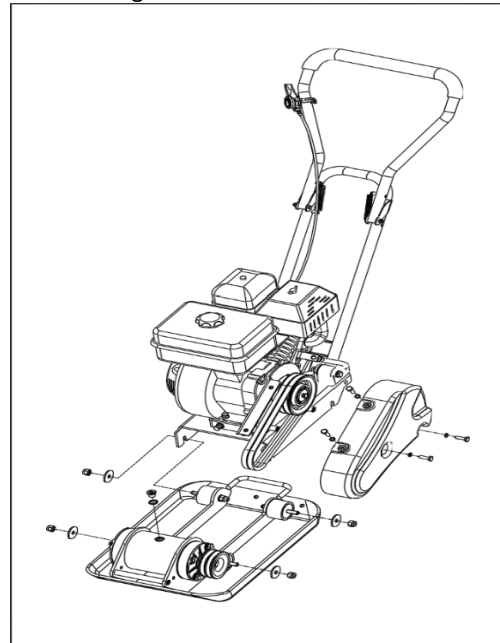

- Lift entire deck with engine from the housing

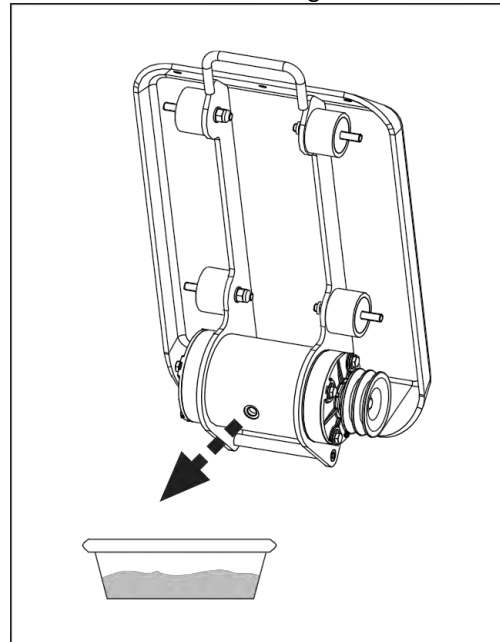

- Remove the pipe plug from the top of the exciter housing. Tilt the housing upside down so that the oil drains from the exciter. Examine oil for metal chips as a warning of future issues.
- Return the plate housing to the upright position
- Fill the exciter housing with Automatic Transmission Fluid Dextron III, Mercon, EXXON (ESSO) NUTO H-32 or its equivalent.

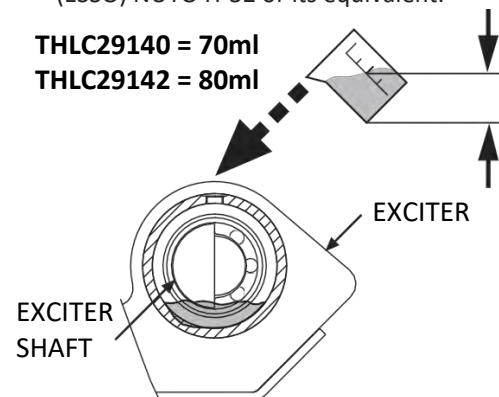

**Do not overfill, overfilling can result in excessive temperatures in the exciter.**

- Apply pipe sealant to the pipe plug and reinstall it into the top of the exciter housing.
- Reinstall the deck, V-belt(s) and belt guard.

## ENGINE MAINTENANCE

Refer to the Engine Manual included with your machine for information on engine maintenance. Your engine manual provides detailed information and a maintenance schedule for performing tasks. All engine enquiries should be raised with the engine manufacturer or one of their approved service dealers.

## STORAGE

If the plate compactor will not be used for a period longer than 30 days, follow the steps below to prepare your unit for storage.

1. Drain the fuel tank completely. Stored fuel can start to go stale in 30 days. Stale fuel has a high gum content and can clog the carburettor and restrict fuel flow.
2. Start the engine & allow it to run until it stops. This ensures no fuel is left in the carburettor. This helps prevent deposits forming inside the carburettor and possible engine damage.
3. While the engine is still warm, but not hot, drain the oil from the engine. Refill with fresh oil of the grade recommended in the Engine Manual.

4. Allow the engine to cool. Remove the spark plug and put 60 ml of SAE-30 high quality motor oil into the cylinder. Pull the starter rope slowly to distribute the oil. Replace the spark plug.



**Remove spark plug & drain all the oil from the cylinder before attempting to start after storage.**

5. Use a clean cloth to clean off the outside of the compactor and to keep the air vents free of obstructions.



**Do not use strong detergents or petroleum-based cleaners when cleaning plastic parts. Chemicals can damage plastics.**



**Do not store the machine containing fuel in a non-ventilated area where fuel fumes may reach flames, sparks, pilot lights or any other ignition sources.**

## LIFTING & TRANSPORT

The 29140 weighs 53kg, the 29142 weighs 63kg.



**WARNING**

**A two-person lift is highly recommended.**

To avoid burns or fire hazards, let the engine cool before lifting or transporting the machine or storing indoors. The unit can be lifted by the handles at the front and back of the unit as shown.

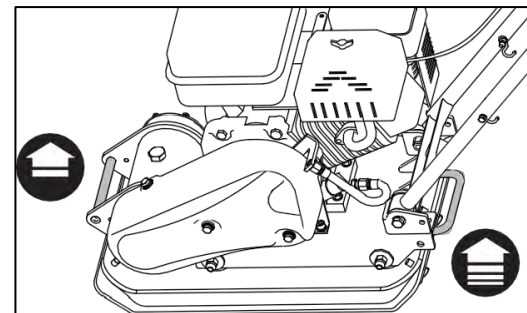

The unit must be transported in the upright position to prevent fuel from spilling. Do not lay the machine on its side or top at any time. Secure or tie down the unit using the lifting handle to prevent the machine from sliding or tipping.



**The machine may fall and cause damage or injury if lifted incorrectly. Lift using handles at the base of the plate**



## TROUBLE SHOOTING

| PROBLEM   | CAUSE   | REMEDY  |
|---|---|---|
| Engine fails to start.  | <ol style="list-style-type: none"> <li>1. Spark plug wire disconnected.</li> <li>2. Out of fuel or stale fuel.</li> <li>3. Throttle control lever not in the correct starting position.</li> <li>4. Choke not in ON Position.</li> <li>5. Blocked fuel line.</li> <li>6. Fouled spark plug.</li> <li>7. Engine flooding.</li> </ol> | <ol style="list-style-type: none"> <li>1. Attach spark plug wire securely to the spark plug.</li> <li>2. Fill with clean, fresh petrol.</li> <li>3. Move throttle control lever to the start position.</li> <li>4. Throttle must be positioned at choke for a cold start.</li> <li>5. Clean the fuel line.</li> <li>6. Clean, adjust gap, or replace.</li> <li>7. Wait a few minutes to restart, but do not prime.</li> </ol> |
| Engine runs erratically.  | <ol style="list-style-type: none"> <li>1. Spark plug wire loose.</li> <li>2. Unit running on CHOKE.</li> <li>3. Blocked fuel line or stale fuel.</li> <li>4. Vent plugged.</li> <li>5. Water or dirt in fuel system.</li> <li>6. Dirty air cleaner.</li> </ol>  | <ol style="list-style-type: none"> <li>1. Connect and tighten the spark plug wire.</li> <li>2. Move the choke lever to OFF.</li> <li>3. Clean the fuel line. Fill the tank with clean, fresh petrol.</li> <li>4. Clear vent.</li> <li>5. Drain fuel tank. Refill with fresh fuel.</li> <li>6. Clean or replace air cleaner.</li> </ol>  |
| Engine overheats  | <ol style="list-style-type: none"> <li>1. Engine oil level low.</li> <li>2. Dirty air cleaner.</li> <li>3. Air flow restricted.</li> </ol>  | <ol style="list-style-type: none"> <li>4. Fill the crankcase with proper oil.</li> <li>5. Clean the air cleaner.</li> <li>6. Remove the blower housing and clean</li> </ol>   |
| Engine will not stop when throttle control is positioned at stop, or engine speed does not increase properly when the throttle control is adjusted. | Debris interfering with the throttle linkage.   | Clean dirt and debris.  |
| Compactor is difficult to control during use (machine jumps or lurches forward)   | Too high engine speed on hard ground.   | Set the throttle lever at a lower speed.  |
| Compactor does not vibrate  | Magnets with excitor are stuck and need releasing.  | Tap excitor cylinder at front of machine with rubber mallet to release magnets.   |

# PARTS DIAGRAM – THLC29140 (1938106002)

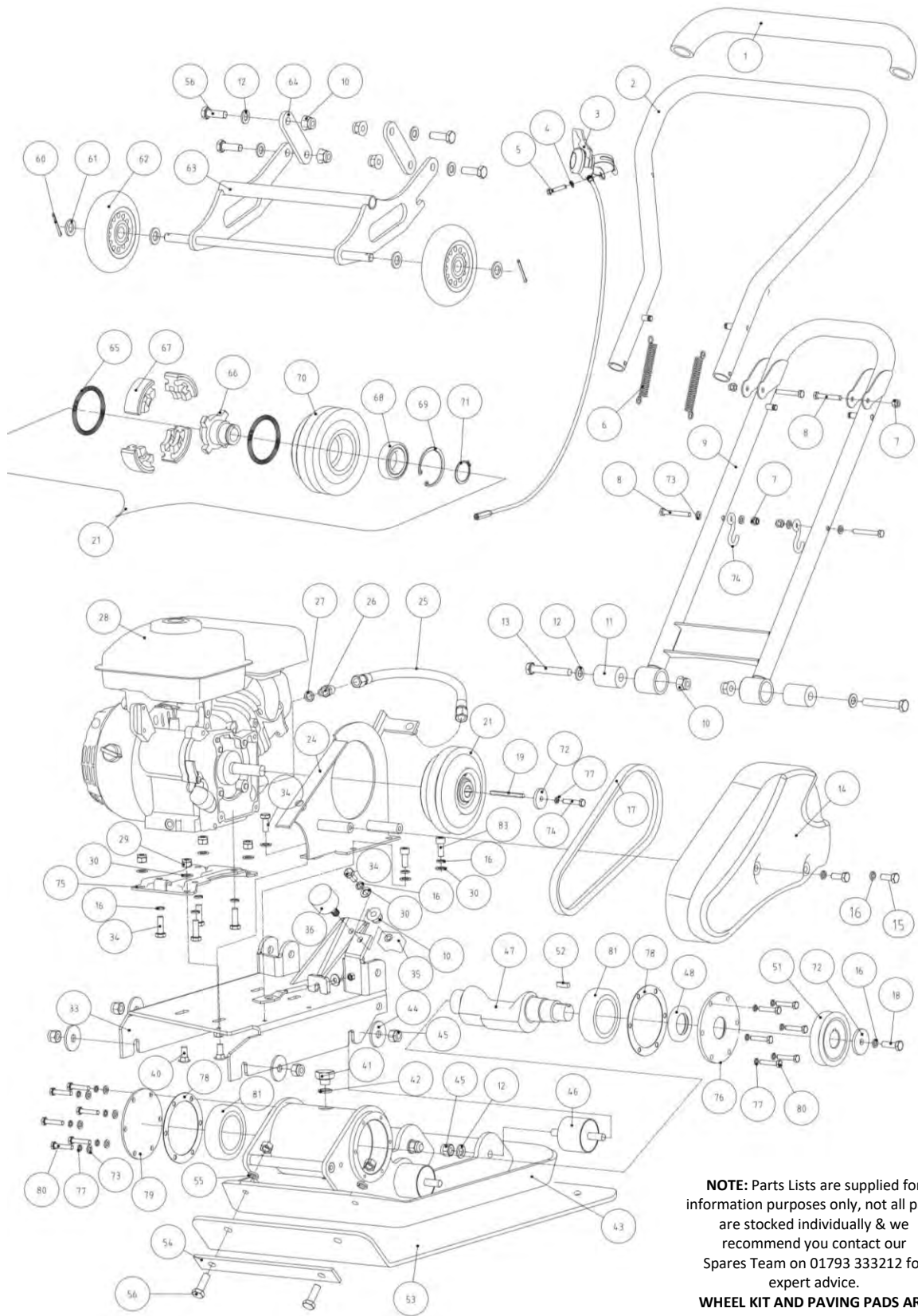

**NOTE:** Parts Lists are supplied for information purposes only, not all parts are stocked individually & we recommend you contact our Spares Team on 01793 333212 for expert advice.

**WHEEL KIT AND PAVING PADS ARE ACCESSORIES AND NOT STANDARD ON THIS PRODUCT**

## PARTS LIST– THLC29140 (1938106002)

| Item No | Part No. | Description                        | Qty | Item No | Part No. | Description       | Qty |
|---------|----------|------------------------------------|-----|---------|----------|-------------------|-----|
| 1       | TH192-1  | Grip                               | 1   | 43      | TH192-43 | Base Plate        | 1   |
| 2       | TH192-2  | Upper Handle                       | 1   | 44      | TH192-44 | Washer            | 4   |
| 3       | TH192-3  | Throttle Control                   | 1   | 45      | TH192-45 | Lock Nut M10      | 4   |
| 4       | TH192-4  | Flat Washer 5                      | 1   | 46      | TH192-46 | Shock Absorber    | 8   |
| 5       | TH192-5  | Bolt M5x25                         | 1   | 47      | TH192-47 | Exciter Shaft     | 1   |
| 6       | TH192-6  | Spring                             | 2   | 48      | TH192-48 | Seal 30x42x7      | 1   |
| 7       | TH192-7  | Lock Nut M6                        | 4   | 51      | TH192-51 | Pulley            | 1   |
| 8       | TH192-8  | Bolt M6x40                         | 4   | 52      | TH192-52 | Key C6x20         | 1   |
| 9       | TH192-9  | Lower Handle                       | 1   | 53      | TH192-53 | Paving Pad        | 1   |
| 10      | TH192-10 | Lock Nut M10                       | 7   | 54      | TH192-54 | Clamp Plate       | 2   |
| 11      | TH192-11 | Rubber Sleeve                      | 2   | 55      | TH192-55 | Lock Washer 10    | 6   |
| 12      | TH192-12 | Flat Washer 10                     | 10  | 56      | TH192-56 | Bolt M10x30       | 10  |
| 13      | TH192-13 | Bolt M10x65                        | 2   | 60      | TH192-60 | Pin 3.2x30        | 2   |
| 14      | TH192-14 | Belt Guard                         | 1   | 61      | TH192-61 | Flat Washer 12    | 4   |
| 15      | TH192-15 | Bolt M8x25                         | 3   | 62      | TH192-62 | Wheels            | 2   |
| 16      | TH192-16 | Lock Washer 8                      | 12  | 63      | TH192-63 | Wheel Bracket     | 1   |
| 17      | TH192-17 | V-Belt                             | 1   | 64      | TH192-64 | Link Plate        | 2   |
| 18      | TH192-18 | Bolt M8x30                         | 1   | 65      | TH192-65 | Spring            | 2   |
| 19      | TH192-19 | Key B5x35                          | 1   | 66      | TH192-66 | Hub               | 1   |
| 21      | TH192-21 | Centrifugal Clutch                 | 1   | 67      | TH192-67 | Clutch Lining     | 4   |
| 24      | TH192-24 | Bracket                            | 1   | 68      | TH192-68 | Ball Bearing 6006 | 1   |
| 25      | TH192-25 | Hose                               | 1   | 69      | TH192-69 | Snap Ring 55      | 1   |
| 26      | TH192-26 | Coupler                            | 1   | 70      | TH192-70 | Clutch Pulley     | 1   |
| 27      | TH192-27 | Washer                             | 1   | 71      | TH192-71 | Snap Ring 30      | 1   |
| 28      | TH192-28 | Engine<br>(Loncin OHV 83cc Euro V) | 1   | 72      | TH192-72 | Washer            | 1   |
| 29      | TH192-29 | Lock Nut M8                        | 4   | 73      | TH192-73 | Flat Washer 6     | 4   |
| 30      | TH192-30 | Washer 8                           | 5   | 74      | TH192-74 | Wheel Kid Pothook | 2   |
| 31      | TH192-31 | Bolt M8x35                         | 1   | 75      | TH192-75 | Engine Link       | 1   |
| 32      | TH192-32 | Nut M8                             | 1   | 76      | TH192-76 | Bearing Cover L   | 1   |
| 33      | TH192-33 | Engine Deck                        | 1   | 77      | TH192-77 | Lock Washer 6     | 13  |
| 34      | TH192-34 | Bolt M8x16                         | 6   | 78      | TH192-78 | Housing Washer    | 2   |
| 35      | TH192-35 | Shock Absorber                     | 1   | 79      | TH192-79 | Bearing Cover R   | 1   |
| 36      | TH192-36 | Shock Absorber                     | 1   | 80      | TH192-80 | Bolt M6x16        | 12  |
| 40      | TH192-40 | Bolt M8x20                         | 4   | 81      | TH192-81 | Ball Bearing      | 2   |
| 41      | TH192-41 | Plug M14x1.5                       | 1   | 83      | TH192-83 | Screw M8x16       | 2   |
| 42      | TH192-42 | Washer 14                          | 1   | 84      | TH192-84 | Bolt M6x30        | 1   |

# PARTS DIAGRAM – THLC29142 (1938105002)

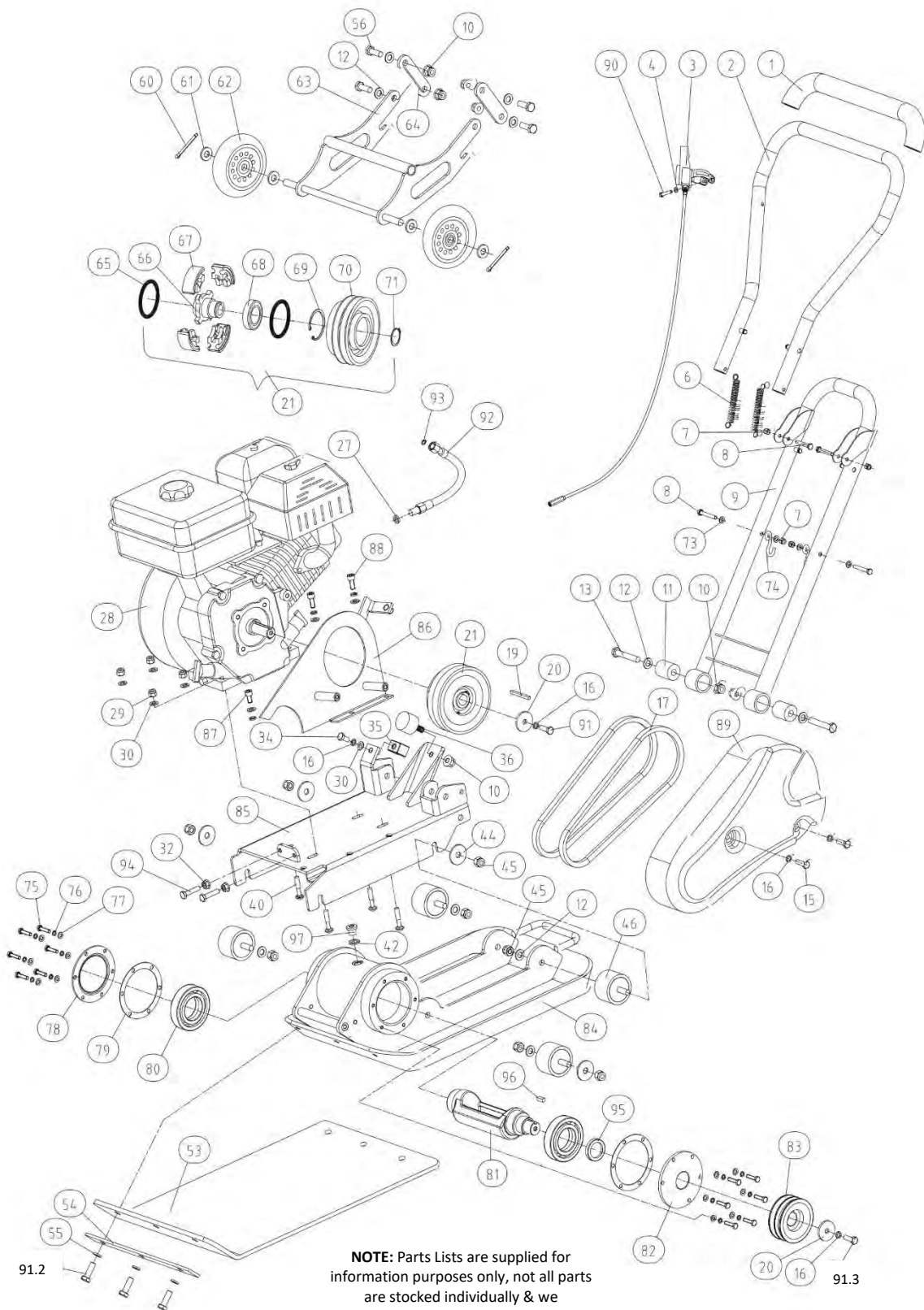

**NOTE:** Parts Lists are supplied for information purposes only, not all parts are stocked individually & we recommend you contact our Spares Team on 01793 333212 for expert advice.

**WHEEL KIT AND PAVING PADS ARE ACCESSORIES AND NOT STANDARD ON THIS PRODUCT**

## PARTS LIST– THLC29142 (1938105001)

| Item Number | Handy Part Number | Description                            | Qty | Item Number | Handy Part Number | Description         | Qty |
|-------------|-------------------|--|-----|-------------|-------------------|---------------------|-----|
| 1           | TH192-1           | Grip                                   | 1   | 62          | TH192-62          | Wheel               | 2   |
| 2           | TH192-2           | Upper Handle                           | 1   | 63          | TH192-63          | Wheel Bracket       | 1   |
| 3           | TH192-3           | Throttle Control                       | 1   | 64          | TH192-64          | Link Plate          | 2   |
| 4           | TH192-4           | Flatt Washer 5                         | 1   | 65          | TH192-65          | Spring              | 2   |
| 6           | TH192-6           | Spring                                 | 2   | 66          | TH193-66          | Hub                 | 1   |
| 7           | TH192-7           | Lock Nut M6                            | 4   | 67          | TH192-67          | Clutch Lining       | 4   |
| 8           | TH192-8           | Bolt M6x40                             | 4   | 68          | TH192-68          | Ball Bearing 6006   | 1   |
| 9           | TH192-9           | Lower Handle                           | 1   | 69          | TH192-69          | Snap Ring 55        | 1   |
| 10          | TH192-10          | Lock Nut M10                           | 7   | 70          | TH193-70          | Clutch Pulley       | 1   |
| 11          | TH192-11          | Rubber Sleeve                          | 2   | 71          | TH192-71          | Snap Ring 30        | 1   |
| 12          | TH192-12          | Flat Washer 10                         | 10  | 73          | TH192-73          | Flat Washer 6       | 12  |
| 13          | TH192-13          | Bolt M10x65                            | 2   | 74          | TH192-74          | Wheel Kit Hook      | 2   |
| 15          | TH192-91-1        | Bolt M8x20                             | 2   | 75          | TH193-75          | Bolt M6x20          | 12  |
| 16          | TH192-16          | Lock Washer 8                          | 13  | 76          | TH193-76          | Spring Washer 6     | 12  |
| 17          | TH193-17          | V-Belt                                 | 2   | 77          | TH193-77          | Flat Washer 6       | 12  |
| 19          | TH192-19          | Key B5x35                              | 1   | 78          | TH193-78          | Bearing Cover Right | 1   |
| 20          | TH193-20          | Washer                                 | 2   | 79          | TH193-79          | Washer              | 2   |
| 21          | TH193-21          | Centrifugal Clutch                     | 1   | 80          | TH193-80          | Bearing 6209        | 2   |
| 27          | TH192-27          | Washer                                 | 1   | 81          | TH192-47          | Exciter Shaft       | 1   |
| 28          |                   | Engine<br>(Loncin 163cc OHV<br>Euro V) | 1   | 82          | TH193-82          | Bearing Cover Left  | 1   |
| 29          | TH192-29          | Lock Nut M8                            | 4   | 83          | TH192-51          | Pulley              | 1   |
| 30          | TH192-30          | Washer 8                               | 13  | 84          | TH193-84          | Base Plate          | 1   |
| 32          | TH192-32          | Nut M8                                 | 2   | 85          | TH193-85          | Engine Deck         | 1   |
| 34          | TH192-34          | Bolt M8x16                             | 1   | 86          | TH193-86          | Bracket             | 1   |
| 35          | TH192-35          | Shock Absorber                         | 1   | 87          | TH193-87          | Screw M8x14         | 1   |
| 36          | TH192-36          | Shock Absorber                         | 1   | 88          | TH193-88          | Screw M8x20         | 2   |
| 40          | TH193-40          | Bolt M8x40                             | 4   | 89          | TH193-14          | Belt Guard          | 1   |
| 42          | TH192-42          | Washer 14                              | 1   | 90          | TH193-90          | Bolt M5x30          | 1   |
| 44          | TH192-44          | Washer                                 | 4   | 92          | TH193-92          | Hose                | 1   |
| 45          | TH192-45          | Lock Nut M10                           | 8   | 93          | TH193-93          | O-Ring              | 1   |
| 46          | TH192-46          | Shock Absorber                         | 4   | 94          | TH193-94          | Bolt M8x45          | 2   |
| 53          | TH193-53          | Paving Pad                             | 1   | 95          | TH193-95          | Seal 30x42x6        | 1   |
| 54          | TH193-54          | Clamp Plate                            | 2   | 96          | TH193-96          | Key B6x18           | 1   |
| 55          | TH192-55          | Lock Washer 10                         | 6   | 97          | TH192-14          | Plug M14x1.5        | 1   |
| 56          | TH193-56          | Bolt M10x30                            | 4   | 91-1        | TH193-91-1        | Bolt M8x25          | 1   |
| 60          | TH193-60          | Pin 2.5x25                             | 2   | 91-2        | TH193-91-2        | Bolt M10x20         | 3   |
| 61          | TH192-61          | Flat Washer 12                         | 4   | 91-3        | TH193-91-3        | Bolt M8x20          | 1   |

# GJ HANDY & CO LTD USER WARRANTY POLICY

## **Users Statement of Warranty**

Each new machine is warranted against defective material or assembly of material under normal usage. The warranty applies to the original purchaser and covers faulty parts and the labour involved in replacing and repairing those parts, which are of original manufacture.

## **Period of Warranty**

### **Webb (excludes Electric Handheld, Dynamic, Heritage, Legacy), Webb Pro, Sanli Engine**

- a) 2 years from the original date of sale to the first domestic user.
- b) 90 days from the original date of sale to the professional/commercial user.
- c) 90 days from the original date of sale when used for hire.
- d) A reduced warranty period of 90 days applies to those items which are subject to normal wear and tear (e.g. but not limited to wheels, tyres, cutter bars, cylinders, cutting blades, blade boss, belts, cables, nylon line & spool, collection bags, spark plugs).
- e) Engines are supplied with a separate warranty to the machine. The engine manufacturers warranty statement which will be supplied within the engine instruction manual. All enquiries and warranty repairs should be discussed with the engine manufacturer or approved warranty repair dealer.
- f) 90 days from the original date of purchase for Replacement Spare Parts (unless normal wear & tear component, which are covered for 30 days).
- g) All machines' must be serviced within the first 12 months from the original date of purchase to comply with the warranty, failure to do so will invalidate the 2nd year of the warranty.

### **Webb Electric Handheld, Webb Dynamic, Heritage & Legacy, The Handy, Mowerland, Q-Garden**

- a) 1 year from the original date of sale to the first domestic user.
- b) 90 days from the original date of sale to the professional/commercial user.
- c) 90 days from the original date of sale when used for hire.
- d) A reduced warranty period of 90 days applies to those items which are subject to normal wear and tear (e.g. but not limited to wheels, tyres, cutter bars, cylinders, cutting blades, blade boss, belts, cables, nylon line & spool, collection bags, spark plugs).
- e) Engines are supplied with a separate warranty to the machine. The engine manufacturers warranty statement which will be supplied within the engine instruction manual. All enquiries and warranty repairs should be discussed with the engine manufacturer or approved warranty repair dealer.
- f) 90 days from the original date of purchase for Replacement Spare Parts (unless normal wear & tear component, which are covered for 30 days).

All warranty repairs must be undertaken by an authorised service dealer. These dealers have been accredited by GJ Handy & Co Ltd and agree to only use genuine parts and follow our repair procedures.

## **Not covered by this warranty**

- a) The warranty policy does not cover any depreciation or damages caused by ordinary wear, rusting or corrosion, lack of correct maintenance or operation, misuse, abuse, lack of transportation or accident.
- b) The warranty policy does not cover any costs necessary for the standard periodic maintenance services instructed by the operator's manual, or service parts replacement which would include oil, filters, tyres, belts, brake linings, fuses, blades, seals and other service parts unless it can be proven that the item has evidence of faulty manufacture.
- c) The warranty policy will not cover failure or damage caused as a result of parts or accessories being modified without the written approval of GJ Handy & Co Ltd.
- d) The warranty policy will not cover the unit if non-genuine parts have been fitted and as a result damage has occurred to the unit.
- e) The warranty policy is non-transferable and is only applicable to the original purchaser.

**Disclaimer**

This warranty is only a remedy for defect of products. GJ Handy & Co Ltd will never warranty in terms of the merchantability or the fitness for a particular purpose.

No person is authorised to make any warranties, representations or promises, expressed or implied, on behalf of GJ Handy & Co Ltd, or to modify the terms conditions or limitation of this warranty policy in any way.

Neither GJ Handy & Co Ltd nor any company affiliated with GJ Handy & Co Ltd shall be liable in any event or manner whatsoever for incidental or consequential damages or injuries, including, but not limited to, loss of crops, loss of profit, out of pocket expenses or profits, rental of substitute equipment or other commercial losses.

**General**

Most warrantable failures show up within the first few weeks of use. These failures are usually straightforward and warranty assessment is relatively easy.

Failures relating to cutter decks and belts need careful investigation, as the cause may not always be straightforward. Look for damage to blades and pulleys especially when the cutter belt or blade boss have snapped or cracked as this could be due to impact damage.

Customers should always refer to the operator/instruction manual when any disputed problem arises, you will find most areas covered within the manual.



## EC DECLARATION OF CONFORMITY

We Handy Distribution Ltd - SN3 5HY (Importer) declare that the product:

**Designation:** 495mm (12") Petrol Compactor Plate

**Model(s):** THLC29140

**Product Number:** 1938106002

**Type/Serial No:** As per rating label on machine

**Complies with the following directives:**

2006/42/EC – Machinery Directive

2000/14/EC Annex VI & 2005/88/EC - Noise Directive

**The conformity assessment procedure followed was in accordance with**

EN 500-4:2011,

**Notified Bodies:**

TÜV Rheinland LGA Products GmbH

**Address(es):**

Zertifizierstelle, Ridlerstraße 65, 80339 München, Germany

**Guaranteed Sound Power Level:**

(L<sub>WA</sub>) 103 dB(A)

**Vibration Level**

17.5 m/s<sup>2</sup>

**Authorised signatory & technical file holder**

**Date:**

21/02/2019

**Signature:**

A handwritten signature in black ink, appearing to read 'S Belcher', written over a horizontal line.

**Name:**

Mr Simon Belcher

**Position:**

Managing Director

**Company:**

Handy Distribution Ltd

**Address:**

Murdock Rd, Dorcan, Swindon, Wiltshire, SN3 5HY.





## EC DECLARATION OF CONFORMITY

We Handy Distribution Ltd - SN3 5HY (Importer) declare that the product:

**Designation:** 530mm (14") Petrol Compactor Plate

**Model(s):** THLC29142

**Product Number:** 1938105002

**Type/Serial No:** As per rating label on machine

**Complies with the following directives:**

2006/42/EC – Machinery Directive

2000/14/EC Annex VI & 2005/88/EC - Noise Directive

**The conformity assessment procedure followed was in accordance with**

EN 500-4:2011,

**Notified Bodies:**

TÜV Rheinland LGA Products GmbH

**Address(es):**

Zertifizierstelle, Ridlerstraße 65, 80339 München, Germany

**Guaranteed Sound Power Level:**

(LWA) 105 dB(A)

**Vibration Level**

10.8 m/s<sup>2</sup>

**Authorised signatory & technical file holder**

**Date:**

21/02/2019

**Signature:**

A handwritten signature in black ink, appearing to read 'S Belcher', written over a horizontal line.

**Name:**

Mr Simon Belcher

**Position:**

Managing Director

**Company:**

Handy Distribution Ltd

**Address:**

Murdock Rd, Dorcan, Swindon, Wiltshire, SN3 5HY.

## NOTES



For spares or support of your Handy product,  
please contact us:

Tel: 01793 333212

Email: [customerservice@handydistribution.co.uk](mailto:customerservice@handydistribution.co.uk)

Monday to Friday

Feb to Oct 8:30am - 5:30pm

Nov to Jan 8.30am - 5.00pm

**To see our range of garden machinery & equipment visit:**

**[www.thehandy.co.uk](http://www.thehandy.co.uk)**

**Making gardening easier & affordable since 1938**

Distributed by Handy Distribution, Murdock Road, Dorcan, Swindon, SN3 5HY