



INSTRUCTION MANUAL

POLY DUMP CART

(200kg Max. Capacity)

Model No: THPDC -- Product No: 1938136001

ASSEMBLY REQUIRED

SAVE THESE INSTRUCTIONS

SPARES & SUPPORT: 01793 333212

Please read & understand this manual, paying attention to the safety instructions, before use.
The manufacturer reserves the right to change the product specification and livery according to continued product improvements.

CONTENTS

SPECIFICATION

IMPORTANT INFORMATION

GENERAL SAFETY INSTRUCTIONS

ASSEMBLY

OPERATION

MAINTENANCE & STORAGE

REPAIRS & SERVICING

PARTS DIAGRAM & LIST

WARRANTY

ASSEMBLY IS REQUIRED – TWO PEOPLE

This product requires assembly before use. See the “Assembly” section for instructions.

Please check that all parts required for the assembly of this spreader are included. If for any reason you believe a part for the assembly is missing or damaged, please contact us.

**If you require any assistance with regards to the contents or operation of
your machine, please contact us:**

TEL: 01793 333212

(MON – FRI 8.00AM TO 5.30PM EXCL. BANK HOLIDAYS)

EMAIL: customerservice@handydistribution.co.uk

SPECIFICATION

The manufacturer reserves the right to change the product specification and livery according to continued product improvements.

Model	THPDC
Product Number	1938136001
Max. Load Capacity (Weight)	200kg (440lb)
Max. Tipping Capacity (Weight)	181kg (399lb)
Poly Tub Dimension	L 106 x W 59 x D 28.5cm
Tyre	Puncture Proof 13x5.00-6 (Not for Highway Use)
Weight	N.W 23kg – G.W 26kg

IMPORTANT INFORMATION

INTENDED USE

This is a garden trolley, therefore extended use over abrasive surfaces (e.g. concrete, tarmac etc.) could cause premature wear on the trolley tyres (Not covered by the manufacturer's warranty).

This product is not intended for commercial use.

Generally acknowledged accident prevention regulations and enclosed safety instructions must be observed. Only perform work described in these instructions for use, any other use is incorrect. The manufacturer will not assume responsibility for damage resulting from such use.

SAFETY SYMBOLS



Safety alert symbol. Used to alert you to potential personal injury hazards. Obey all safety messages that follow this symbol to avoid possible injury.



DANGER

Indicates an imminently hazardous situation which, if not avoided, will result in serious injury.



WARNING

Indicates a potentially hazardous situation which, if not avoided, could result in serious injury



CAUTION

Indicates a potentially hazardous situation which, if not avoided, may result in minor or moderate injury.

CAUTION

Used without the safety alert symbol indicates a potentially hazardous situation which, if not avoided, may result in property damage.

GENERAL SAFETY INSTRUCTIONS

Read and understand the owner's manual and labels affixed to the product. Learn its application and limitations as well as the specific potential hazards. Retain these instructions for future reference. The operator is responsible for following the warnings & instructions in this manual and on the product.



DURING OPERATION

- This is a garden trolley, therefore extended use over abrasive surfaces (e.g concrete, tarmac etc) could cause premature wear on the trolley tyres.
-
- Always ensure that your load is evenly distributed over the front and rear axles & four wheels.
- **Do not at any time allow anyone to sit or stand on the Trolley.**
- Do not allow children to play on, stand upon or climb in the Trolley.
- Always inspect the Trolley before use to ensure it is in good working condition.
- Immediately replace or repair damaged or worn parts before using the Trolley.
- Always check and tighten hardware and assembled parts before operation.
- Do not exceed the equipment maximum load capacity of 200kg (440lb), tipping capacity 181kg (399lb).
- Distribute all loads evenly over both axles and four wheels.
- Do not try to carry loads that make the Cart unstable.
- Avoid large holes and ditches when using the Cart.
- Be careful when operating on steep gradients (hills) the Trolley may tip over.
- Only tow with recommended vehicles (Lawn/Garden Tractors and ATVs).
- Always operate at a reduced speed in rough terrain, along creeks, ditches and on hillsides.
- Do not operate close to creeks, ditches and public roads.
- To avoid personal injury and/or equipment damage **DO NOT EXCEED 10 MPH.**
- Always use caution when loading and unloading the Trolley.
- Always secure and lock the Cart to the vehicle hitch before operating.

CRUSH AND CUT HAZARDS

- Always keep your hands and feet clear from moving parts while operating the equipment.
- Always keep the work area clean and clear when operating

ASSEMBLY

Remove the machine and contents from the carton. Be sure the carton is empty before disposing.

If you require any assistance with regards to the contents of the lawnmower contact us:

Tel: 01793 333212 - Mon – Fri 8.00am – 5.30pm (excl. Bank Holidays)

Email: customerservice@handydistribution.co.uk

Tools Required – Large flat head screwdriver, socket set or two adjustable spanners.

Step 1

Assemble front bracket to front frame using M8X20 bolts (TH140-12), M8 lock (TH140-16), ID 8mm washers (TH140-19).

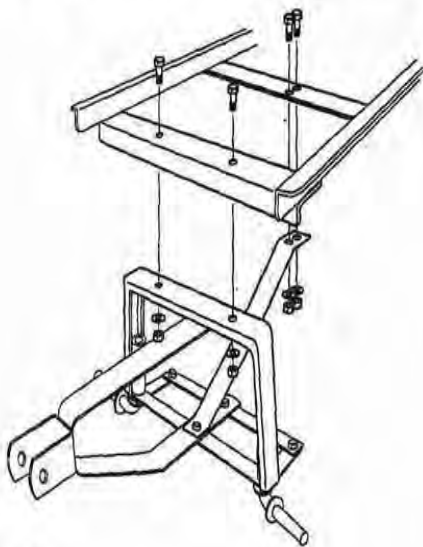

Step 2

Assemble rear bracket to rear frame and tub using Round head M8X30 bolts (TH140-13), M8 lock nuts (TH140-16), 4PCS ID 8mm wide wing washers (TH140-18) on the base of the tub. Use one washer inside the tub and one underneath the nut (see Exploded Drawing for Assembly on page 4)

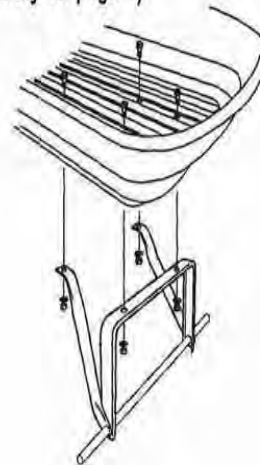

Step 3

Assemble lock to tub using Round head M8X20 bolts (TH140-14), M8 lock nuts (TH140-16), 4PCS ID 8mm wide wing washers (TH140-18) on the base of the tub. Use one washer inside the tub and one underneath the nut (see Exploded Drawing for Assembly on page 4).

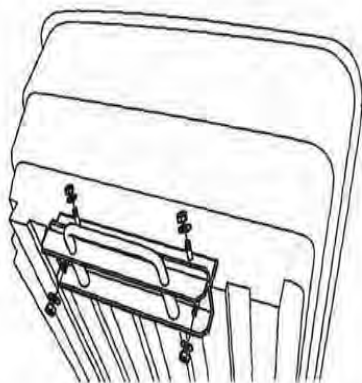

Step 4

Place tub into its dump position. Remove the front screws from the rear frame. Take the front axle and frame and slide it over the rear frame where the screws were just removed. Once aligned, reinsert the screws and refit the nuts. The rear frame, front frame, and tub should now all be connected.

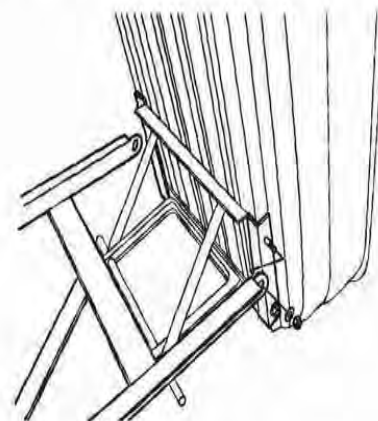

Step 5

Assemble the wheels using the M12 lock nuts (TH140-17), spacers (TH140-21), and washers (TH140-20).

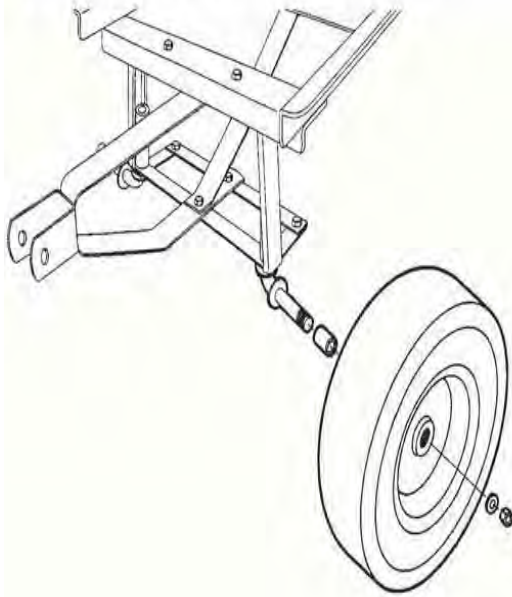

Step 6

Assemble the handle to the yoke using M8X60 bolt (TH140-15), M8 lock nut (TH140-16), and ID 8mm washer (TH140-19).

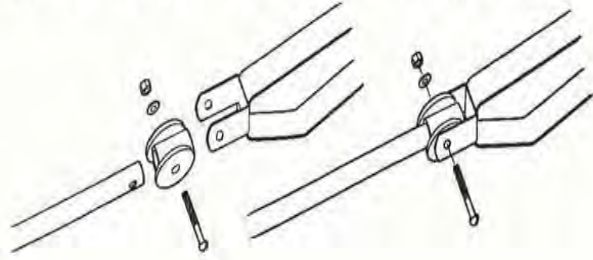

Using the Dumping Feature

To operate the dumping feature, pull the dumping release handle outward to release the plastic bed from the locking mechanism. Lift up the release handle to raise the cart into the dumping position.

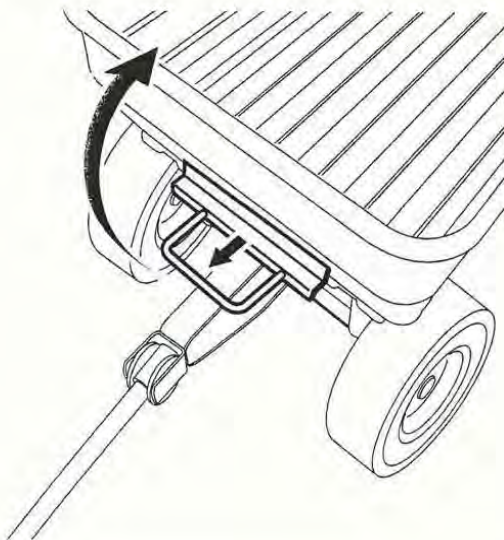

Returning the Plastic Bed to the Lowered Position

Move the plastic bed back down to the lowered position. Make sure the dumping release handle is locked into place when the cart is in the lowered position.

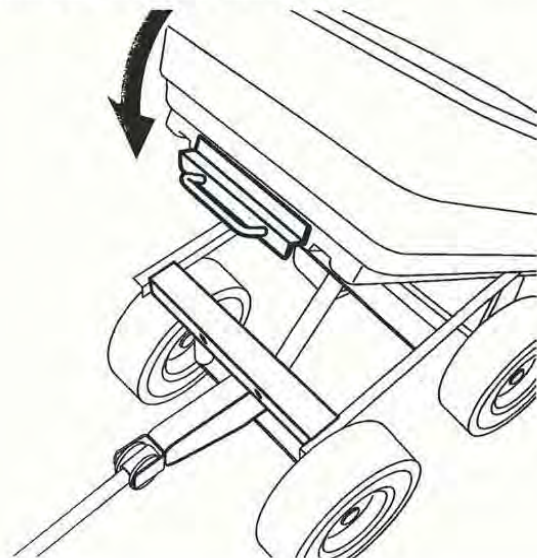

⚠ CAUTION

**DO NOT EXCEED MAXIMUM OVERALL LOAD CAPACITY 200KGS
MAXIMUM DUMPING LOAD CAPACITY 181KGS.**

MAINTENANCE & STORAGE



WARNING

Improper maintenance & storage of the Trolley may void your warranty.

LUBRICATE

Maintenance spray or multi-purpose grease can be applied to the wheel axle prior to long-term storage. Oiling is not necessary.

CLEANING

After each use, thoroughly clean material out of the cart.
Rinse/dry inside and outside of the Trolley after each use.

STORING

Never allow material to stay in the hopper for extended periods of time.
Before storing, ensure that the spreader is clean and dry.
Store indoors or in a protected area during severe weather and in the winter months.

CHECK ALL NUTS, BOLTS AND FASTENING

Periodically check all fastenings are tight & secure.

NEVER EXCEED LOAD CAPACITY

To avoid damaging the spreader, never exceed the rated load capacity of 200kg (440lbs) or tipping capacity of 181kg (399lbs)

IMPORTANT:

Only use the manufacturer's original replacement parts. Non-original replacement parts will invalidate your warranty and may result in a safety hazard or poor operation. Parts are available by calling 01793 333212.

REPAIRS & SERVICING

Users of this product should only undertake actions described in this manual, unless otherwise instructed by the manufacturer. All other repairs and servicing should only be undertaken by an approved service/repair dealer. Your nearest approved service/repair dealer can be found at www.thehandy.co.uk.

When repairing the product, always use approved replacement Handy Parts or those which are technically identical. Using high quality replacement parts avoid the risk of accidents, damage to the product and invalidating the manufacturer's warranty.

Replacement parts lists are supplied towards the back of this manual.

PARTS DIAGRAM & LIST – THPDC (1938136001)

NOTE: Parts Lists are supplied for information purposes only, not all parts are stocked individually & we recommend you contact our Spares Team on 01793 333212 for expert advice.

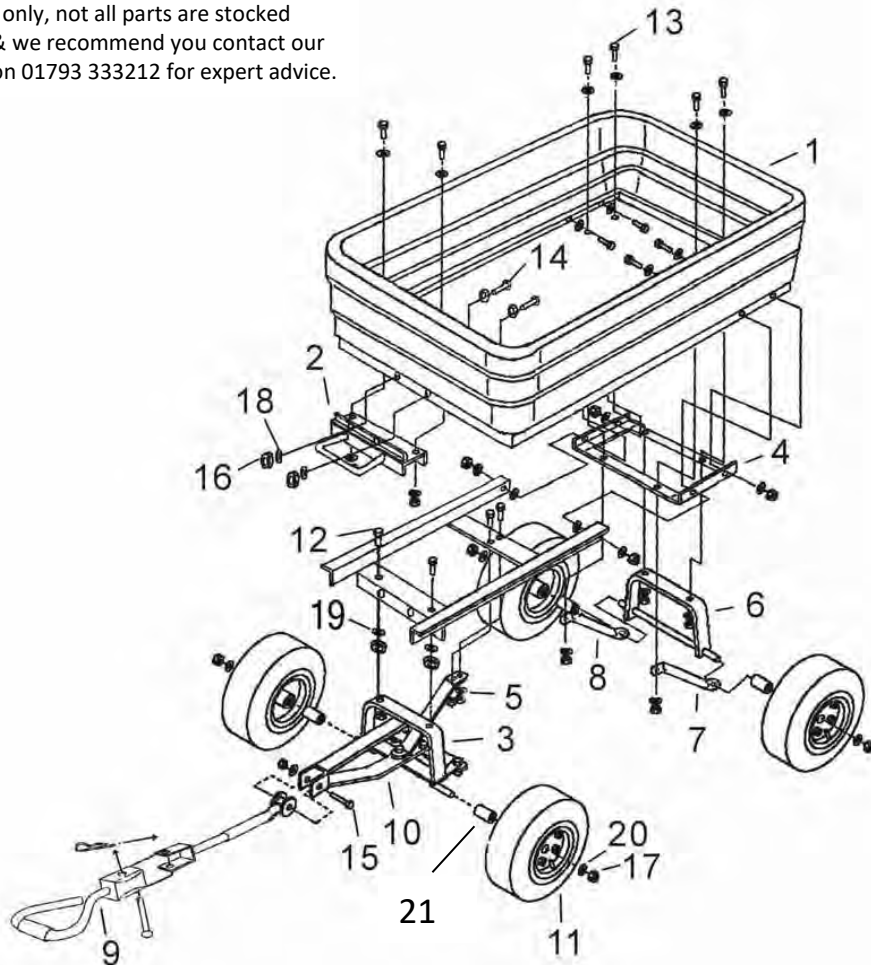

No.	Part No.	Description	QTY
1	TH140-1GM	Tub	1
2	TH140-2GM	Lock	1
3	TH140-3GM	Front Frame	1
4	TH140-4GM	Rear Frame	1
5	TH140-5GM	Front Bracket Assembly	1
6	TH140-6GM	Rear Bracket	1
7	TH140-7GM	Left Rear Brace	1
8	TH140-8GM	Right Rear Brace	1
9	TH140-9GM	Handle	1
10	TH140-10	Coupling	1
11	TH140-11	Wheel	4

No.	Part No.	Description	QTY
12	TH140-12	Bolt M8x20	4
13	TH140-13	Round Head Bolt M8x30	4
14	TH140-14	Round Head Bolt M8x20	4
15	TH140-15	Round Head Bolt M8x60	1
16	TH140-16	Lock Nut M8	13
17	TH140-17	Lock Nut M12	4
18	TH140-18	Wide Wing Washer 8mm	16
19	TH140-19	Washer 8mm	5
20	TH140-20	Washer 12mm	4
21	TH140-21	Spacer	4
	TH140-22GM	Locking Handle	1
	TH140-FIXING KIT	Fixing Kit	

GJ HANDY & CO LTD USER WARRANTY POLICY

Users Statement of Warranty

Each new machine is warranted against defective material or assembly of material under normal usage. The warranty applies to the original purchaser and covers faulty parts and the labour involved in replacing and repairing those parts, which are of original manufacture.

Period of Warranty

All Webb & Webb Pro machines plus Sanli engines.

- a) 2 years from the original date of sale to the first domestic user.
- b) 90 days from the original date of sale to the professional/commercial user.
- c) 90 days from the original date of sale when used for hire.
- d) A reduced warranty period of 90 days applies to those items which are subject to normal wear and tear (e.g. but not limited to wheels, tyres, cutter bars, cylinders, bottom blades, belts, cables, grass bags, spark plugs).
- e) Engines as per the manufacturer's warranty statement which will be supplied with the machine.
- f) 90 days from the original date of purchase for Replacement Spare Parts (unless normal wear & tear component, which are covered for 30 days).
- g) All machines' must be serviced within the first 12 months from the original date of purchase to comply with the warranty, failure to do so will invalidate the 2nd year of the warranty.

All Handy, Mowerland and Q-Garden products.

- a) 1 year from the original date of sale to the first domestic user.
- b) 90 days from the original date of sale to the professional/commercial user.
- c) 90 days from the original date of sale when used for hire.
- d) A reduced warranty period of 90 days applies to those items which are subject to normal wear and tear (e.g. but not limited to wheels, tyres, cutter bars, cylinders, bottom blades, belts, cables, collection bags, spark plugs).
- e) Engines as per the manufacturer's warranty statement which will be supplied with the machine.
- f) 90 days from the original date of purchase for Replacement Spare Parts (unless normal wear & tear component, which are covered for 30 days).

All warranty repairs must be undertaken by an authorised service dealer. These dealers have been accredited by GJ Handy & Co Ltd and agree to only use genuine parts and follow our repair procedures.

GJ HANDY & CO LTD USER WARRANTY POLICY

Not covered by this warranty

- a) The warranty policy does not cover any depreciation or damages caused by ordinary wear, rusting or corrosion, lack of correct maintenance or operation, misuse, abuse, lack of transportation or accident.
- b) The warranty policy does not cover any costs necessary for the standard periodic maintenance services instructed by the operator's manual, or service parts replacement which would include oil, filters, tyres, belts, brake linings, fuses, blades, seals and other service parts unless it can be proven that the item has evidence of faulty manufacture.
- c) The warranty policy will not cover failure or damage caused as a result of parts or accessories being modified without the written approval of GJ Handy & Co Ltd.
- d) The warranty policy will not cover the unit if non-genuine parts have been fitted and as a result damage has occurred to the unit.
- e) The warranty policy is non-transferable and is only applicable to the original purchaser.

Disclaimer

- a) This warranty is only a remedy for defect of products. GJ Handy & Co Ltd will never warranty in terms of the merchantability or the fitness for a particular purpose.
- b) No person is authorised to make any warranties, representations or promises, expressed or implied, on behalf of GJ Handy & Co Ltd, or to modify the terms conditions or limitation of this warranty policy in any way.
- c) Neither GJ Handy & Co Ltd nor any company affiliated with GJ Handy & Co Ltd shall be liable in any event or manner whatsoever for incidental or consequential damages or injuries, including, but not limited to, loss of crops, loss of profit, out of pocket expenses or profits, rental of substitute equipment or other commercial losses.

General

- a) Most warrantable failures show up within the first few weeks of use. These failures are usually straightforward and warranty assessment is relatively easy.
- b) Failures relating to cutter decks and belts need careful investigation, as the cause may not always be straightforward. Look for damage to blades and pulleys especially when the cutter belt or blade boss have snapped or cracked as this could be due to impact damage.
- c) Customers should always refer to the operator/instruction manual when any disputed problem arises, you will find most areas covered within the manual.

For spares or support of your handy product,
please contact us:

Tel: 01793 333212

(Mon – Fri 8.00am to 5.30pm excl. Bank Holidays)

Email: customerservice@handydistribution.co.uk

To see our range of garden machinery & equipment visit:

www.thehandy.co.uk

Making gardening easier & affordable since 1938

Distributed by Handy Distribution, Murdock Road, Dorcan, Swindon, SN3 5HY