



# INSTRUCTION MANUAL

## 38" (96.5CM) TOWED LAWN SWEEPER

MODEL NO: THTLS38 -- PRODUCT NO: 1938119001

EN - ORIGINAL INSTRUCTIONS

ASSEMBLY REQUIRED

SAVE THESE INSTRUCTIONS

SPARES & SUPPORT: 01793 333212

### FOR YOUR SAFETY

Please read & understand this manual, paying attention to the safety instructions, before use.

Incorrect use of the product could put the operator or machine in danger.

Whilst every effort has been made to ensure the accuracy of information contained in this manual, our policy of continuous improvement determines the right to make modifications without prior warning.

Images used are for illustration purposes only

### *Copyright Notice*

Copyright © Handy Distribution

Permission is granted to reproduce this publication for personal & educational use only.

Commercial copying, redistribution, hiring or lending is prohibited.

No part of this publication may be stored in a retrieval system or transmitted in any other form or means without written permission from Handy Distribution.

In all cases this copyright notice must remain intact.

## **CONTENTS**

**SPECIFICATIONS**

**IMPORTANT INFORMATION**

**GENERAL SAFETY INSTRUCTIONS**

**COMPONENTS**

**ASSEMBLY**

**OPERATION & ADJUSTMENT**

**MAINTENANCE**

**PARTS DIAGRAM & LIST**

**WARRANTY**

**NOTES**

### **ASSEMBLY IS REQUIRED**

This product requires assembly before use. See the "Assembly" section for instructions.

Please check that all parts required for the assembly of this spreader are included. If for any reason you believe a part for the assembly is missing or damaged, please contact us.

**If you require assistance with regards to the contents or operation of the machine, please contact us:**

**TEL: 01793 333212**

**EMAIL: [customerservice@handydistribution.co.uk](mailto:customerservice@handydistribution.co.uk)**

**(MON – FRI 8.00AM TO 5.30PM EXCL. BANK HOLIDAYS)**

## SPECIFICATIONS

The manufacturer reserves the right to change the product specification and livery according to continued product improvements.

<b>Model</b>	<b>THTLS38</b>
<b>Product Number</b>	<b>1938119001</b>
Weight	31kg
Working Width	38" (96.5cm)
Hopper Capacity	280 Litre
Wheel	10"

## IMPORTANT INFORMATION

### INTENDED USE

The product is intended for domestic gardens. This product is not intended for commercial use. Generally acknowledged accident prevention regulations and enclosed safety instructions must be observed. Only perform work described in these instructions for use, any other use is incorrect. The manufacturer will not assume responsibility for damage resulting from such use.

## GENERAL SAFETY INSTRUCTIONS

**Read and understand the owner's manual and labels affixed to the product. Learn its application and limitations as well as the specific potential hazards. Retain these instructions for future reference. The operator is responsible for following the warnings & instructions in this manual and on the product.**

### READ THE MACHINE MANUAL

Read the vehicle owner's manual and vehicle safety rules to know how to operate the vehicle before using this equipment.

### STAY ALERT

Do not operate the machine while under the influence of drugs, alcohol, or any medication that could affect your ability to use it properly. Do not use this machine when you are tired or distracted from the job at hand. Be aware of what you are doing at all times. Use common sense.

### USERS

Never allow children to operate the towing vehicle or de-thatcher. Do not allow adults to operate without having read these instructions.

### PASSENGERS

Do not allow anyone to ride or sit on the de-thatcher frame or on the towing vehicle.

### BEWARE BYSTANDERS/PETS

Keep the area of operation clear of all persons, particularly children and also pets.

### HANDLE WITH CARE

Always handle with care and wear sturdy footwear when operating this attachment.

### AVOID DANGEROUS CONDITIONS

Make sure there is adequate surrounding workspace. Cluttered areas invite injuries. Keep your work area clean with sufficient light. Keep the area around the machine clear of obstructions, grease, oil, rubbish & other debris which could cause persons to fall onto moving parts.

### INSPECT YOUR MACHINE

Check all bolts, nuts & screws for tightness before each use, especially those securing guards & drive mechanisms. Vibration during use, may cause these to loosen. Replace damaged, missing or failed parts before using.

Warning labels carry important information.

### CRUSH AND CUT HAZARDS

Always keep your hands and feet clear from moving parts while operating the equipment. Always keep the work area clean and clear when operating.

### CONDITIONS

Always operate up and down a slope, never across the face of a slope. This equipment should be operated at reduced speed on rough terrain, along creeks and ditches and on hillsides, to prevent tipping and loss of control. Do not drive too close to a creek or a ditch. Do not tow this equipment

on a highway or any other public thoroughfare. Always begin with the transmission in first (low) gear & the engine at low speed. Gradually increase the speed as conditions permit. The vehicle braking and stability may be affected with the sweeper attached. Be aware of changing conditions on slopes. Refer to safety rules in the vehicle owner's manual, concerning safe operation on slopes.

#### **DRESS CORRECTLY**

Do not wear loose clothing, gloves, scarfs, neckties or jewelry (rings, wrist watches), which can be caught in moving parts.

#### **DO NOT OVERREACH**

Never stand on the machine. Serious injury could occur if tipped or moving parts are unintentionally contacted. Do not store anything above or near the machine, where anyone might stand on the machine to reach them.

#### **AVOID INJURY FROM UNEXPECTED ACCIDENT**

Keep hands & feet out of the way of all moving parts. Do not place any part of your body or any tool e.g. in moving parts of the machine during operation.

#### **DO NOT FORCE TOOL**

Always work within the rated capacity. Do not operate for a purpose for which it was not intended.

#### **MAINTAIN YOUR MACHINE WITH CARE**

Clean the machine immediately after use. Keep the machine clean to ensure it operates to its full & safest performance. When maintaining this machine, only the manufacturer's original replacement parts should be used. The use of non-original manufacturer parts may invalidate your warranty.

#### **PROTECT THE ENVIRONMENT**

Take left over materials to an authorised collection point or follow the stipulations in the country where the machine is used. Do not discharge into drains, soil or water.

#### **STORE IDLE EQUIPMENT**

When not in use, the machine should be stored in a dry location, out of direct sunlight. Keep the machine away from children & others not qualified.

#### **OPERATION SPEED**

Do not exceed 6mph, to avoid personal injury

and/or equipment damage.

## **SAFETY SYMBOLS**



Read & understand the operator's manual before using the machine. Failure to follow instructions could result in death or serious injury.



Risk of slicing. Keep hands out of the way of all moving parts.



Wear protective gloves to protect your hands



Wear foot protection



Safety alert symbol. Used to alert you to potential personal injury hazards. Obey all safety messages that follow this symbol to avoid possible injury.



#### **DANGER**

Indicates an imminently hazardous situation which, if not avoided, will result in serious injury.



#### **WARNING**

Indicates a potentially hazardous situation which, if not avoided, could result in serious injury



#### **CAUTION**

Indicates a potentially hazardous situation which, if not avoided, may result in minor or moderate injury.

#### **CAUTION**

Used without the safety alert symbol indicates a potentially hazardous situation which, if not avoided, may result in property damage.

## COMPONENTS

Before assembling the machine, lay out all of the components as shown below:

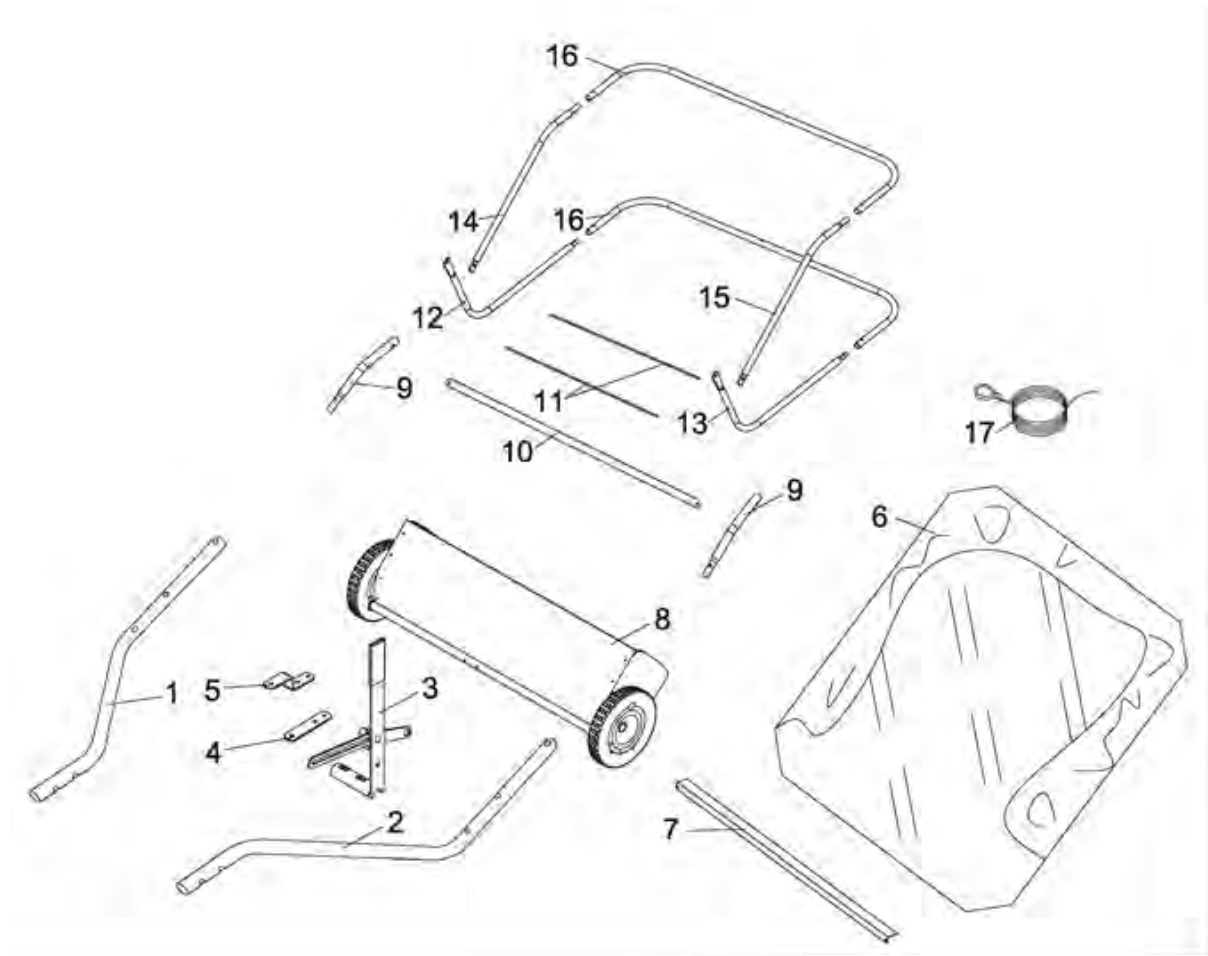

1.	Hitch Tube R.H.	10.	Bag Frame Strap
2.	Hitch Tube L.H.	11.	Hopper Support Rod x2
3.	Handle Assembly	12.	Lower Hopper Side Tube R.H.
4.	Hitch Bracket (Straight)	13.	Lower Hopper Side Tube L.H.
5.	Hitch Bracket	14.	Upper Hopper Side Tube R.H.
6.	Hopper	15.	Upper Hopper Side Tube L.H.
7.	Connecting Rod	16.	Rear Hopper Tube x2
8.	Sweeper Housing Assembly	17.	Rope
9.	Bag Arm Tube x2		

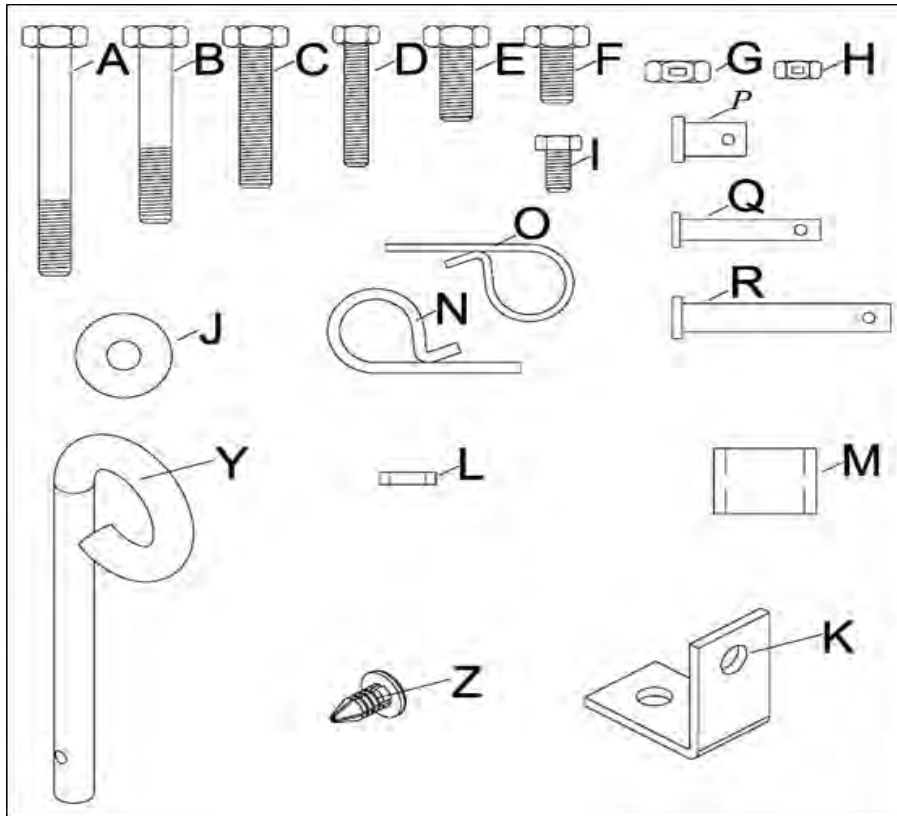

<b>A.</b>	Hex Bolt M8x65 x2	<b>K.</b>	Angle Bracket
<b>B.</b>	Hex Bolt M8x50 x2	<b>L.</b>	Adjustable Pole Spacer
<b>C.</b>	Hex Bolt M8x40 x2	<b>M.</b>	Hitch Spacer x2
<b>D.</b>	Hex Bolt M6x35 x4	<b>N.</b>	R Pin $\varnothing 3$ x5
<b>E.</b>	Hex Bolt M8x20	<b>O.</b>	R Pin $\varnothing 2$ x4
<b>F.</b>	Hex Bolt M8x16	<b>P.</b>	Clevis Pin $\varnothing 9.5 \times 25$ x2
<b>G.</b>	Nylon Lock Nut M8 x8	<b>Q.</b>	Clevis Pin $\varnothing 6 \times 37$ x4
<b>H.</b>	Nylon Lock Nut M6 x6	<b>R.</b>	Clevis Pin $\varnothing 8 \times 59.5$ x2
<b>I.</b>	Hex Bolt M6x12 x2	<b>Y.</b>	Hitch Pin
<b>J.</b>	Big Flat Washer $\varnothing 8$	<b>Z.</b>	Plastic Plug x4

## ASSEMBLY

Remove the hardware pack and all loose parts from the carton and verify that all the components are included. If you are missing any parts, please contact us on 01793 333212 for assistance.

**Note:** Right hand (R.H.) and left hand (L.H.) are determined from the operators' position while seated on the Tractor.

### SWEEPER ASSEMBLY

#### STEP 1

Assemble the angle bracket to the sweeper housing using an M8x16 hex bolt and an M8 hex lock nut. Make sure the bracket is attached as shown and aligned straight with the housing before tightening.

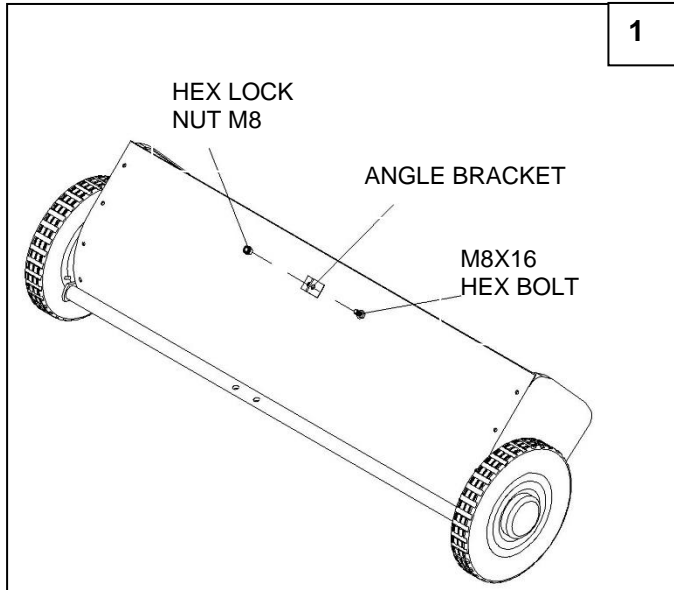

#### STEP 2

Assemble the R.H Hitch Tube to the sweeper housing using an M6x35 Hex Bolt and M6 Lock Nut.

**Do not tighten yet.** Repeat for the L.H hitch tube.

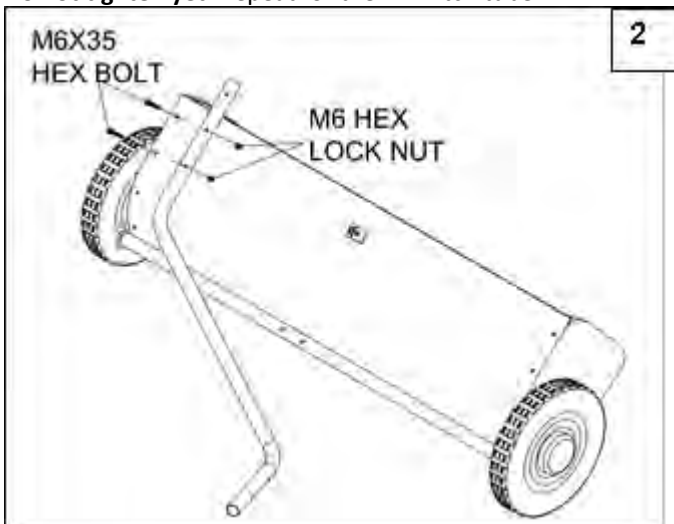



**STEP 3**

Fasten the hitch tubes together using two M8x65 Hex Bolts and M8 Lock Nuts. **Do not tighten yet.**

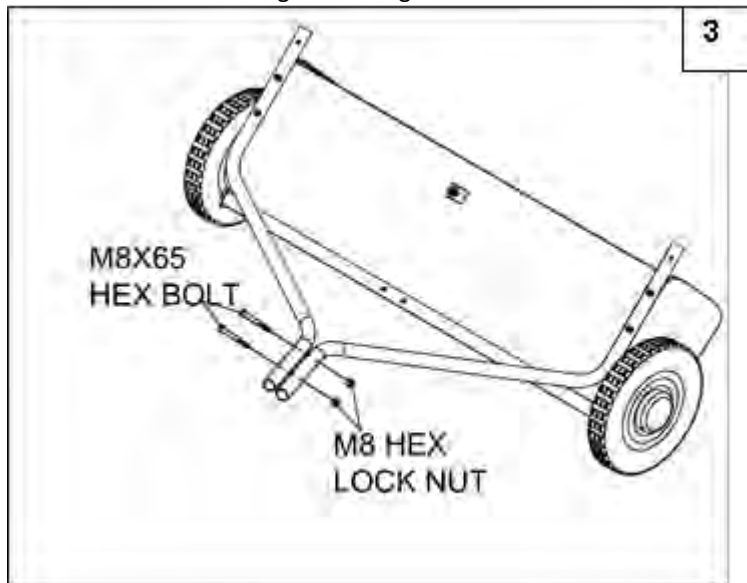

If your tractor hitch has 279mm to 330mm ground clearance refer to Image 4. If your tractor hitch has 203mm to 279mm ground clearance refer to Image 5

**STEP 4**

Attach the hitch brackets to the hitch tubes using two M8x50 hex bolts and M8 hex lock nuts. The bolts should be inserted either side of the front hitch tube bolt. **Do not tighten yet.**

**STEP 5**

Tighten the four bolts fastening the hitch tubes to the sweeper housing. Next, tighten the two bolts fastening the ends of the hitch tubes together. Finally, tighten the two bolts fastening the hitch brackets to the hitch tubes.

**STEP 6**

Insert the hitch pin through the spacers and hitch brackets, and secure with the hair cotter pin.

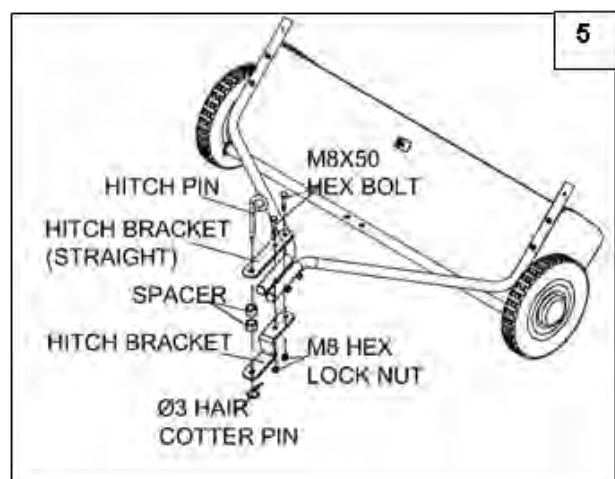
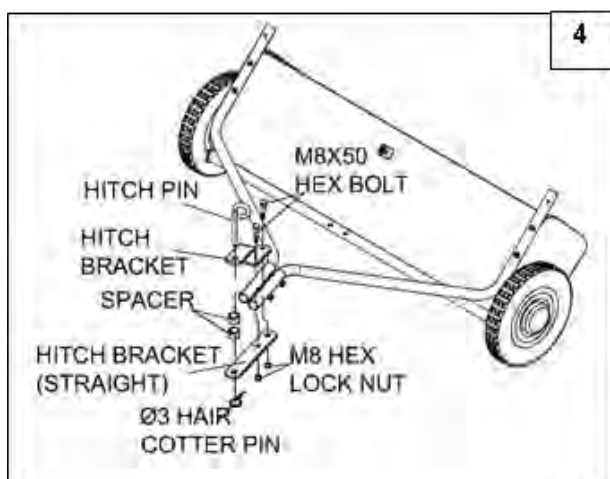

**STEP 7**

Attach the height adjustment handle to the height adjustment tube as shown in figure 6. Use two M8x40 hex bolts and M8 lock nuts. **Do not tighten yet.**

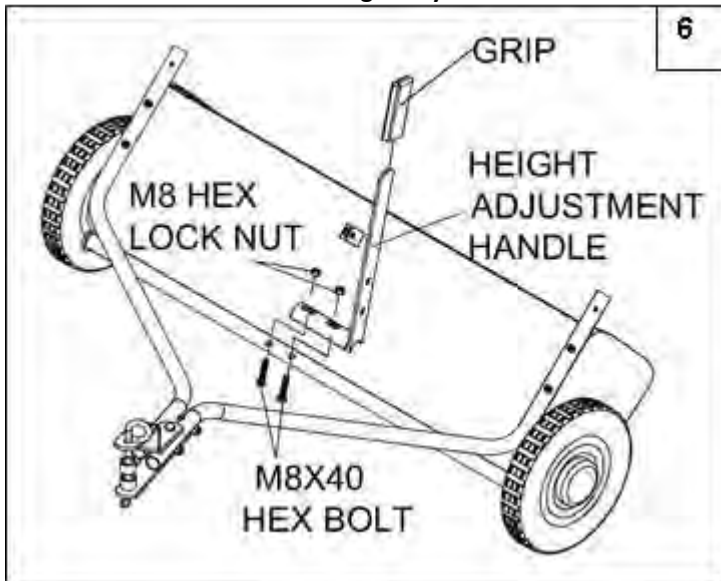

**STEP 8**

Insert an M8x20 hex bolt through the angle bracket. Place onto the bolt (in order) the spacer bushing, the height adjustment strap, an Ø8 big flat washer and an M8 hex lock nut. **Tighten.**

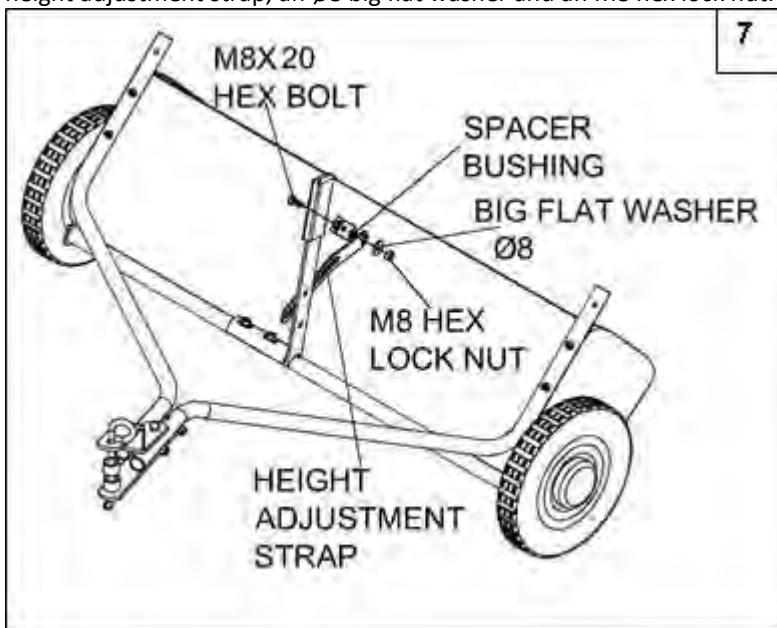

**STEP 9**

Insert an M8x30 carriage bolt through the height adjustment handle. Place on the bolt in this order a wear washer, the height adjustment strap, another wear washer, a big flat washer and finally a plastic knob. Tighten the nuts securing the height adjustment handle.

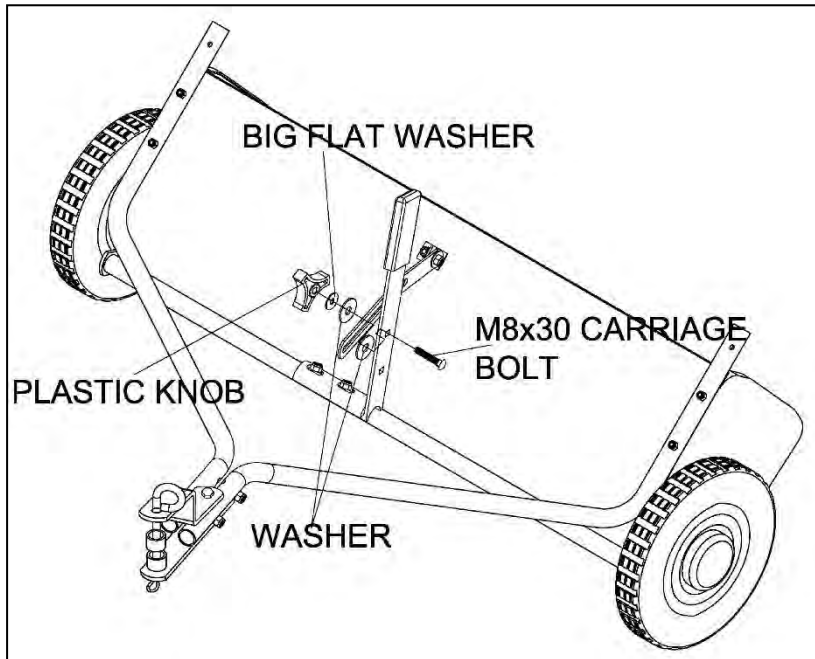

**STEP 10**

Assemble the Connecting Rod to the sweeper housing by using two sets of M6x12 Hex Bolts and M6 Lock Nuts.

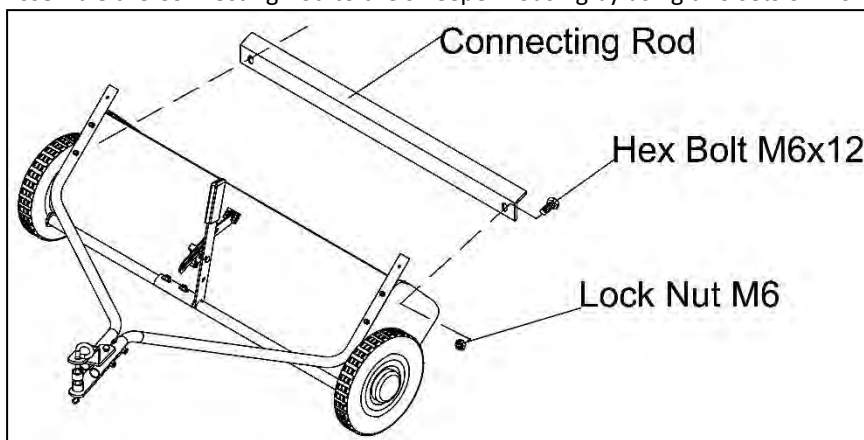

## HOPPER ASSEMBLY

### STEP 11

Turn a rear hopper tube so that the brace holes in the middle of the tube face down. Slide the tube through the two loops sewn into the top rear seam inside the hopper bag.

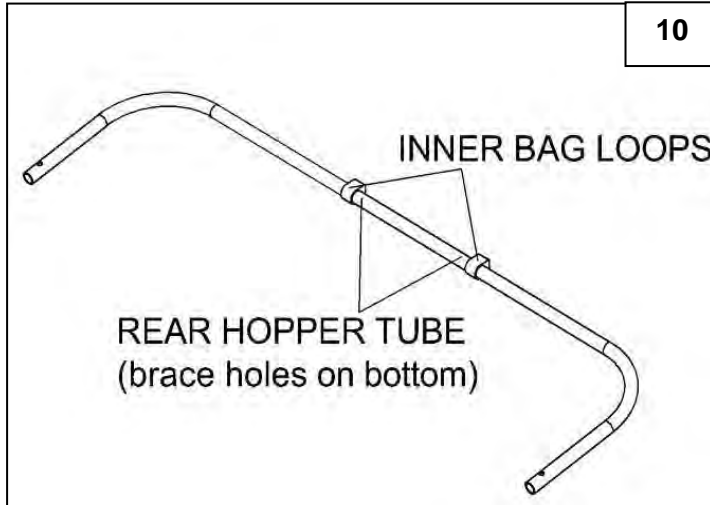

### STEP 12

Insert the two upper hopper side tubes through the stitched flaps on each side of the hopper bag.

### STEP 13

Attach the ends of the rear hopper tubes onto the ends of the upper hopper side tubes

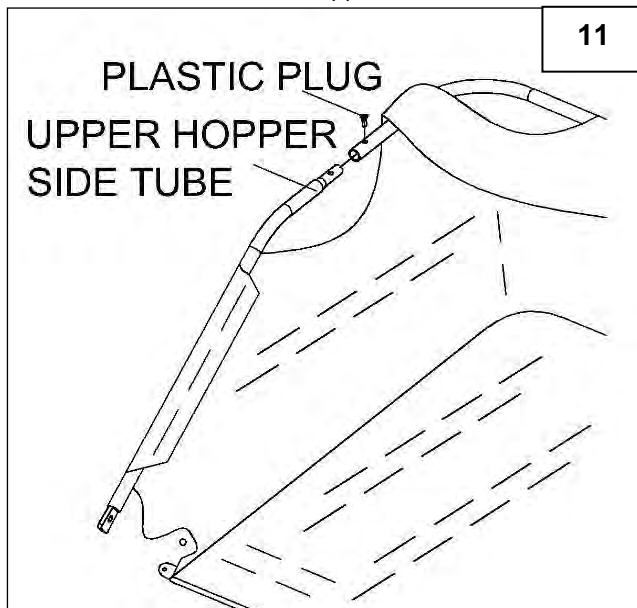

**STEP 14**

Turn the second rear hopper tube so that the brace holes in the middle of the tube face up. Attach the ends of the rear hopper tube onto the ends of the lower hopper side tubes. Fasten together using plastic plugs.

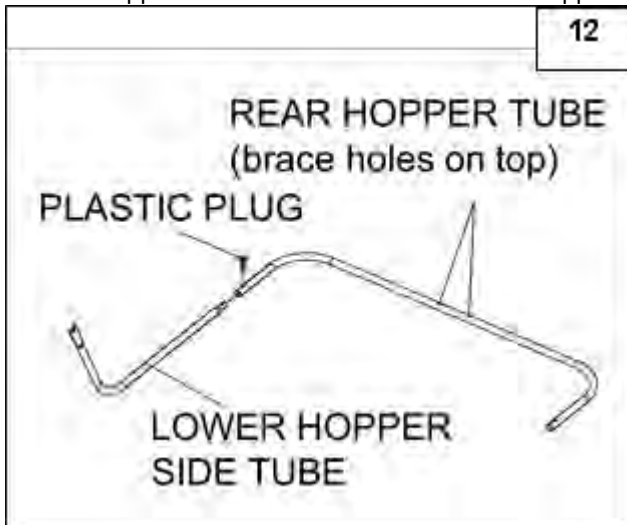

**STEP 15**

Place the assembled lower hopper tubes into the bottom of the hopper bag.

**STEP 16**

Attach the ends of the lower hopper side tubes to the inside of the upper side tubes using two  $\varnothing 9.5 \times 25$  clevis pins inserted from the inside, and two hair cotter pins  $\varnothing 3$ .

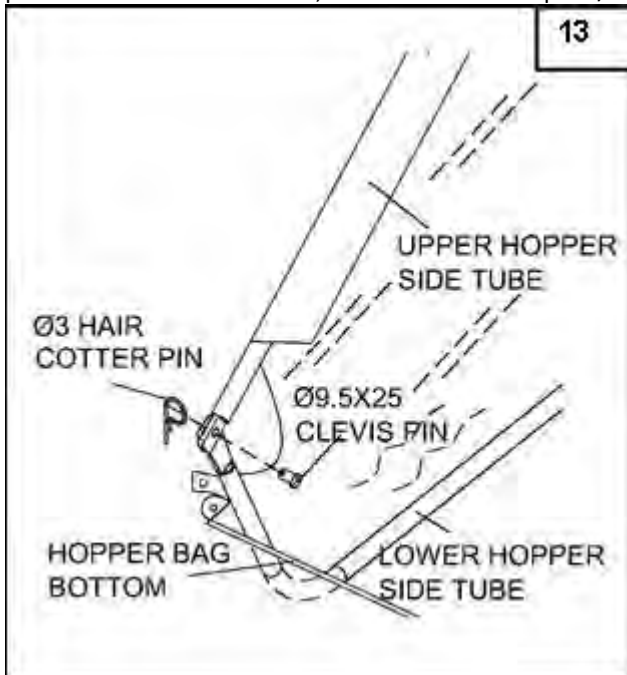

**STEP 17**

Insert the bag frame strap into the stitched sleeve along the front edge of the bag bottom.

**STEP 18**

Attach the bag frame strap to the lower hopper side tubes using two  $\text{Ø}6 \times 37$  clevis pins and two hair cotter pins  $\text{Ø}2$ .

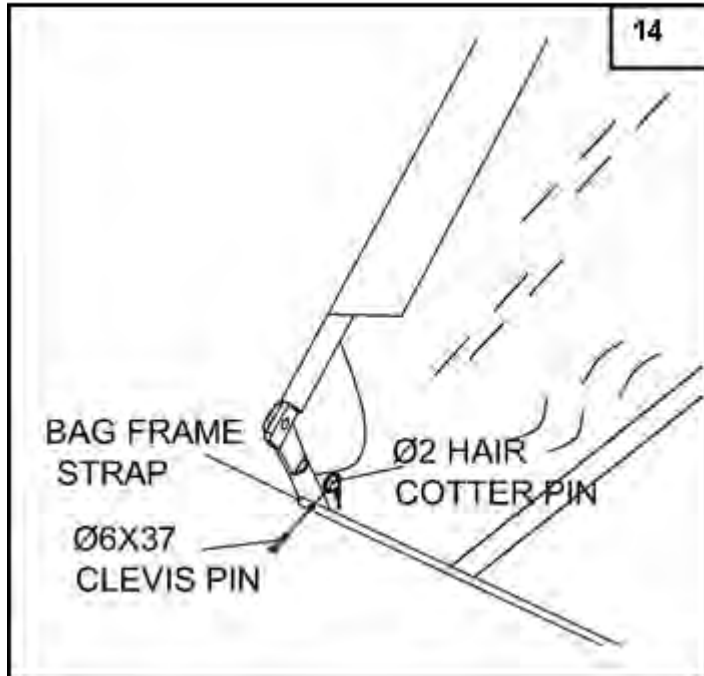

**STEP 19**

Secure the bag corners around the lower hopper side tubes by snapping the bag flaps to the bag bottom on both sides.

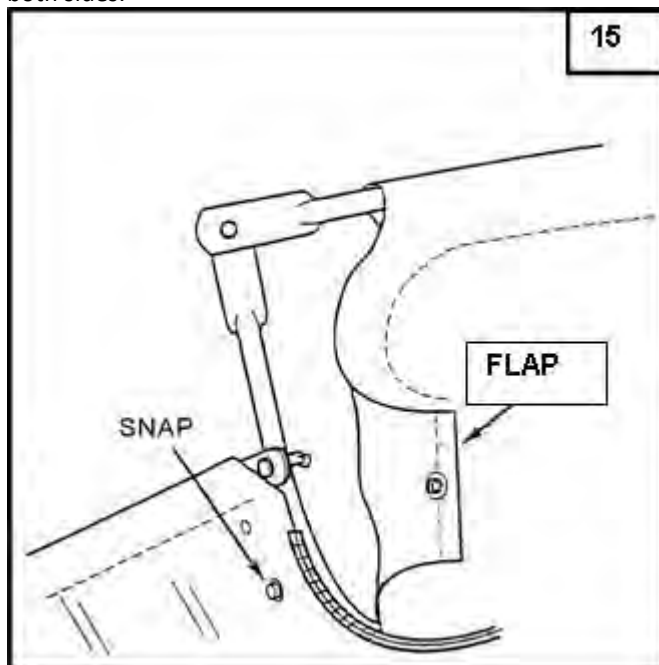

**IMPORTANT:** Do not over bend the support rods during the following step. Over bending will cause the steel rods to lose supporting tension.

**STEP 20**

Tip the hopper onto its back to assemble the two hopper support rods. Bend the rods just enough to fit the ends of each rod into the holes in the upper and lower rear hopper tubes.

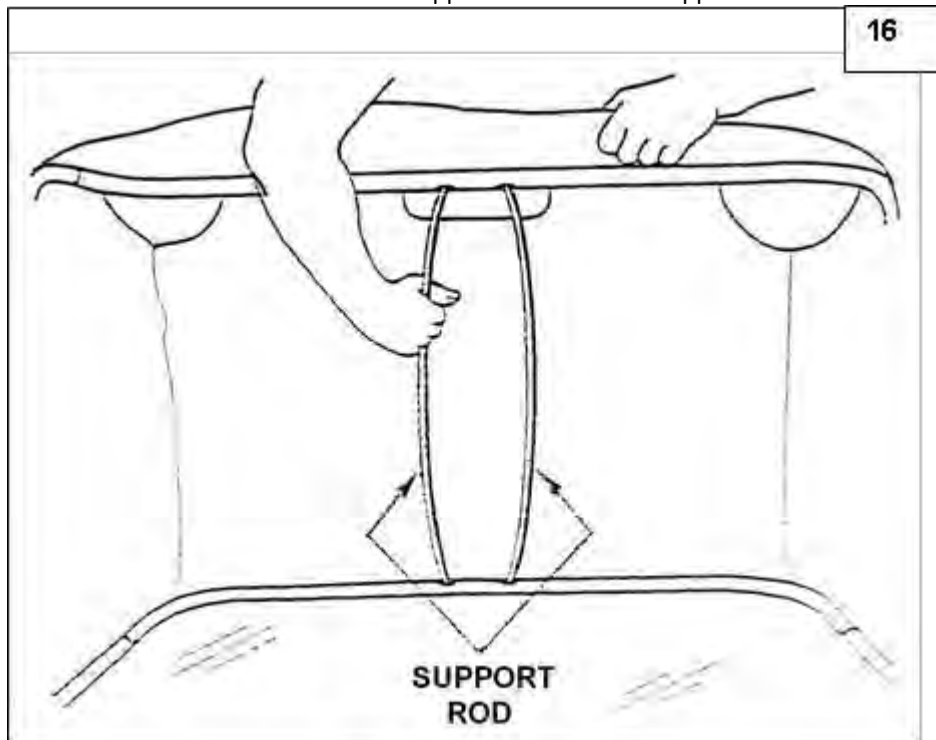

**STEP 21**

Feel along the stitched flap on the hopper bag to locate the lower hole in each upper hopper side tube. Make a hole through both sides of the stitched flaps in line with the lower hole; ideally you should use a bradawl.

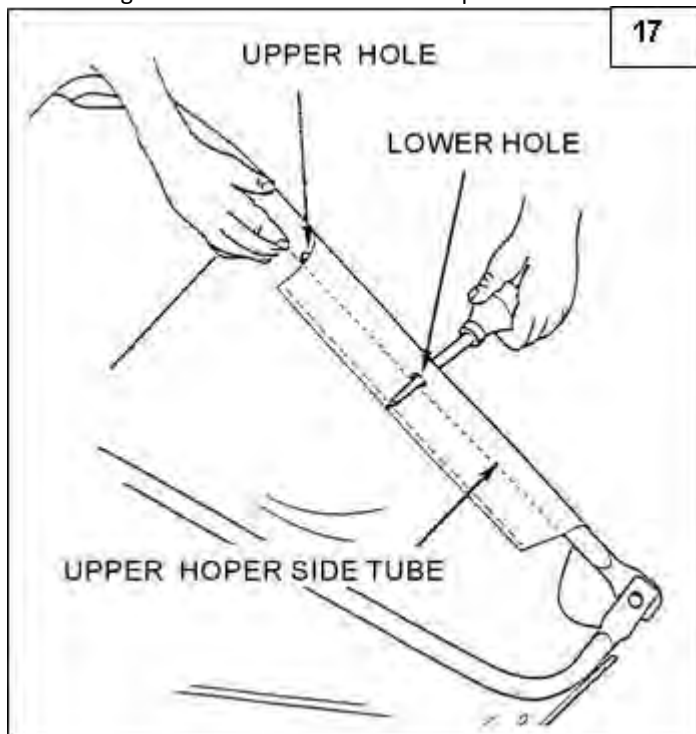

**STEP 22**

Insert a  $\varnothing 8 \times 59.5$  clevis pin through the lower hole in each upper hopper side tube. Next assemble a bag arm tube onto each clevis pin and secure it with a hair cotter pin  $\varnothing 3$ .

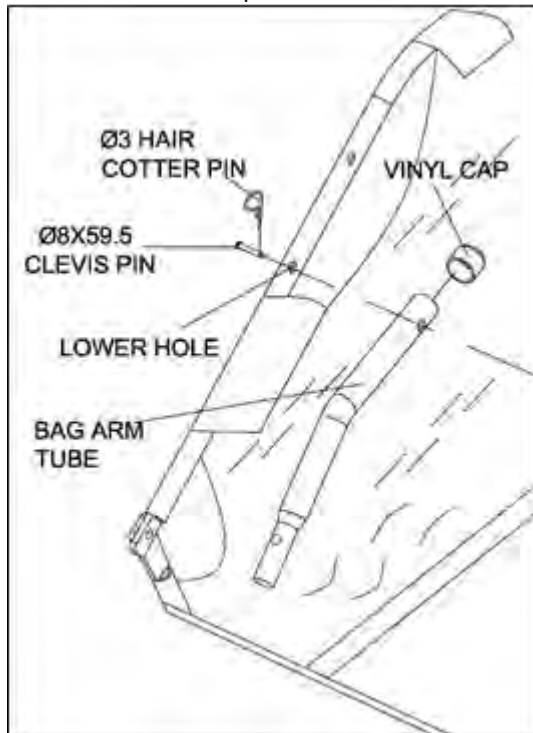

**STEP 23**

Secure the rope to the centre of the top rear hopper tube.

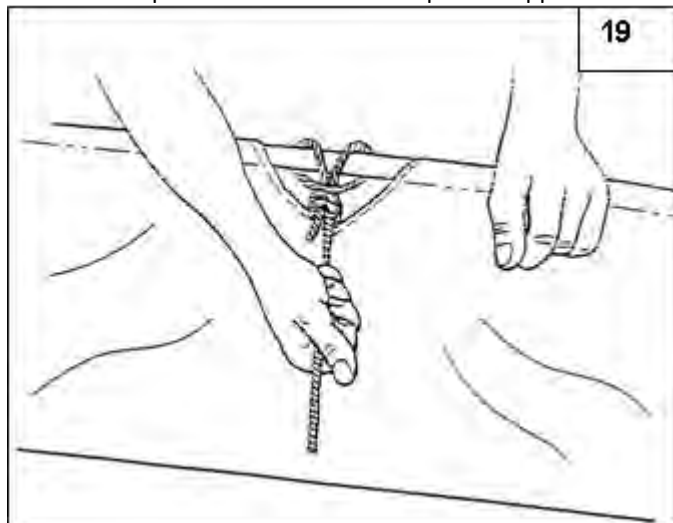



**STEP 24**

To attach the hopper bag to the sweeper, slide the ends of the bag arm tubes into the ends of the sweeper's hitch tubes and secure with two  $\varnothing 6 \times 37$  clevis pins and hair cotter pins  $\varnothing 2$ .

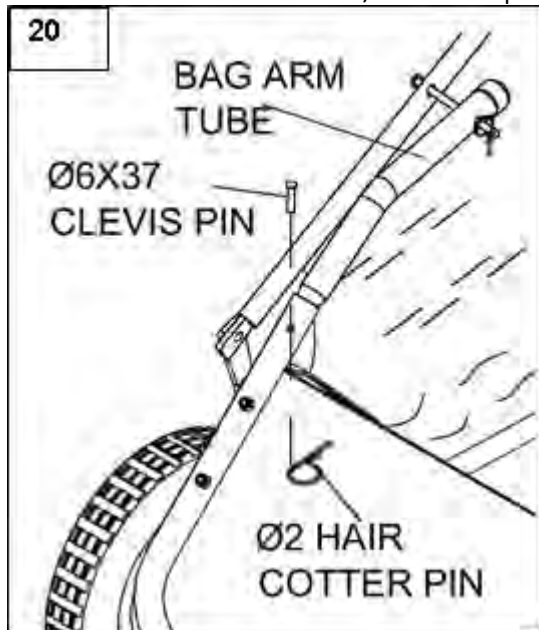

## OPERATION / ADJUSTMENT



### **DANGER**

The product must only be put into operation if no defects are found. It is crucial that defective parts are replaced before the product is used again. Check the safety equipment and the safe condition of the product: Check all parts to make sure that they fit tightly. Check whether there are any visible defects: broken parts, cracks, etc.



- Never attach the rope to your body. The rope may wrap around the brushes or other rotating parts and injure you. Only attach the rope to the tow vehicle. Do not touch the rope while the vehicle is in motion.
- Never allow children to handle the sweeper
- Never allow anyone to ride on the sweeper
- Always wear footwear when working with the sweeper
- Never operate the sweeper if foreign matter is stuck in the blades/brushes. Turn off the tow vehicle engine, remove the foreign matter and check for damage, If the sweeper is damaged, repair before continuing to operate.

### **ATTACHING THE SWEEPER TO THE TOW VEHICLE**

- Park the tow vehicle and sweeper on level ground.
- Set the height adjustment handle to middle of its adjustment.
- Attach the sweeper so that the hopper is as parallel to the ground as possible and the underside clears the ground by at least 12.7cm (5").
- Insert the hitch pin through the sweeper hitch brackets and towing eye of the tow vehicle and secure with the cotter pin.

### **EMPTYING THE HOPPER**

- Stop the tow vehicle and turn off the engine.
- Tip the hopper by pulling the rope.
- Release carefully to rehouse hopper to frame.

## MAINTENANCE

### **LUBRICATE**

Lubricate the wheel bearings once during the season. Remove the centre hub cap and apply a few drops of multi-purpose grease. Lubricate the brush axle at the beginning and end of the season with multi-purpose grease. Clean and grease drive gears every two years. Remove the centre hub cap, lock nut, washer and wheel.

### **CLEANING**

After each use thoroughly clean the machine with a stiff brush.

### **STORING**

Before storing, ensure that the machine is clean and dry.

Store in a dry or protected area and coat exposed metal with light oil when not in use.

### **CHECK ALL NUTS, BOLTS AND FASTENING**

Before each use check all fastenings are tight & secure.

### **ONLY USE MANUFACTURER APPROVED PARTS**

If a part needs replacing, only use the manufacturer's original parts. Non-original replacement parts will invalidate your warranty and may result in a safety hazard or poor operation.

## SERVICE

### **REPLACE WORN BRUSHES**

Remove the hopper. Remove the brush assembly and replace with manufacturer approved replacements.

# PARTS DIAGRAM & LIST

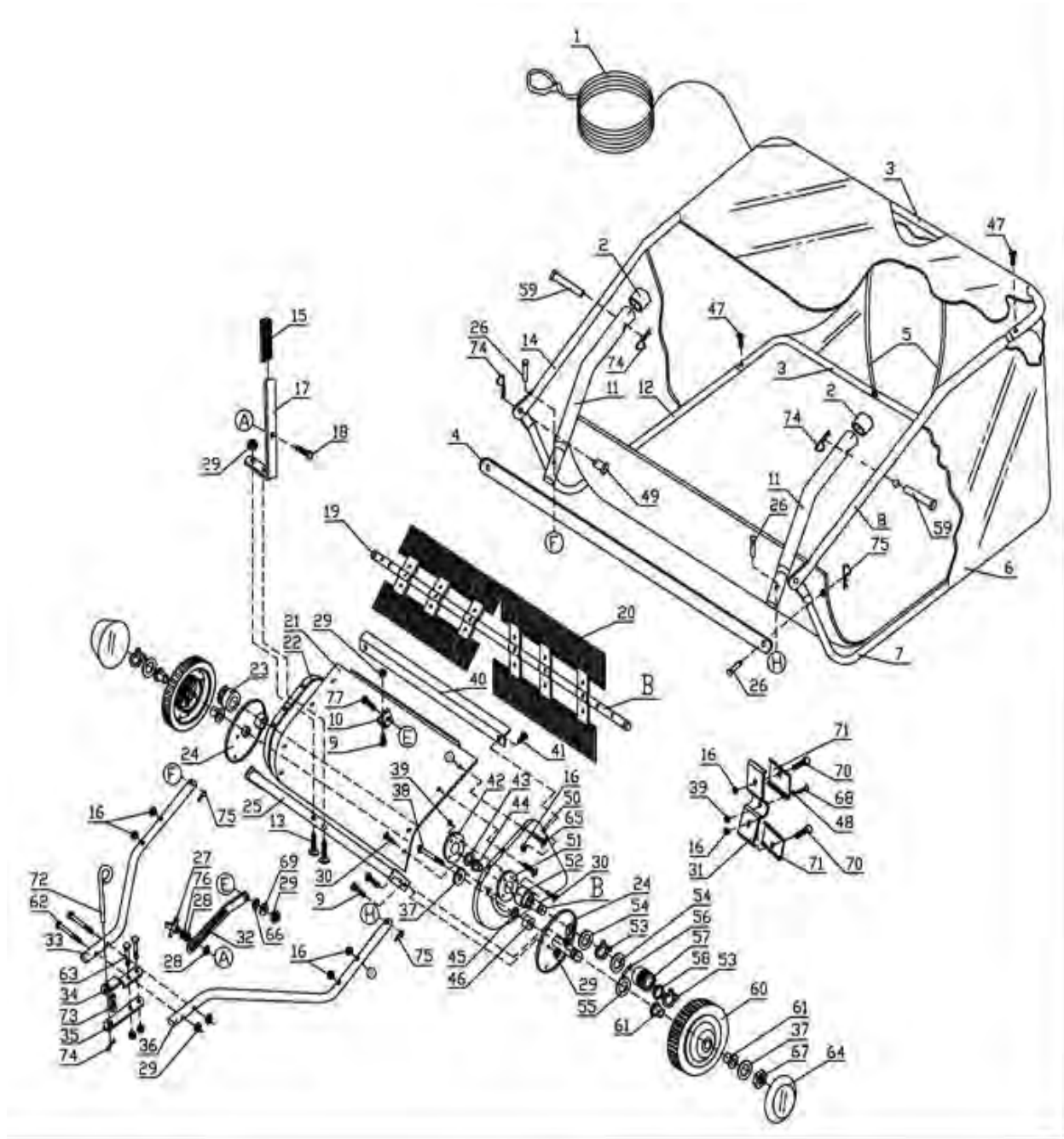

## PARTS LIST

No.	Part No.	Description	Qty	No.	Part No.	Description	Qty
-----	----------	-------------	-----	-----	----------	-------------	-----

1	TH181-1	Hopper Rope	1	40	TH181-40	Connecting Rod	1
2	TH181-2	Vinyl Cap	2	41	TH181-41	Hex Bolt M6x12	2
3	TH181-3GM	Hopper Frame Tube (Rear)	2	42	TH181-42	Dust Cover Retainer	2
4	TH181-4GM	Bag Frame Strap	1	43	TH181-43	Inside Star Washer	2
5	TH181-5	Hopper Support Rod	2	44	TH181-44	Brush Shaft Bushing	2
6	TH181-6	Hopper Bag	1	45	TH181-45	Spacer Bushing	2
7	TH181-7GM	Lower Hopper Frame (L.H.)	1	46	TH181-46	Spacer for Axle	2
8	TH181-8GM	Upper Hopper Frame (L.H.)	1	47	TH181-47	Plastic Bolt	4
9	TH181-9	Hex Bolt M8x16	5	48	TH181-48	Star Washer Ø5	6
10	TH181-10	Angle Bracket	1	49	TH181-49	Clevis Pin C	2
11	TH181-11	Bag Arm Tube	2	50	TH181-50	End Plate (L.H.)	1
12	TH181-12GM	Lower Hopper Frame (R.H.)	1	51	TH181-51	Special Washer	2
13	TH181-13	Hex Bolt M8x40	2	52	TH181-52	Bushing	2
14	TH181-14GM	Upper Hopper Frame (R.H.)	1	53	TH181-53	Retaining Ring Ø15	4
15	TH181-15	Height Adjust Grip	1	54	TH181-54	Adj. Washer A	4
16	TH181-16	Lock Nut M6	18	55	TH181-55	Adj. Washer C	2
17	TH181-17	Height Adjustment Handle	1	56	TH181-56	Dowel Pin (Drive)	2
18	TH181-18	Carriage Bolt M8x30	1	57	TH181-57	Pinion Gear (L.H.)	1
19	TH181-19	Brush Shaft	1	58	TH181-58	Adj. Washer B	2
20	TH181-20	Brush	4	59	TH181-59	Clevis Pin D	2
21	TH181-21	Wrapper	1	60	TH181-60	Wheel & Tyre Assembly	2
22	TH181-22	End Plate (R.H.)	1	61	TH181-61	Wheel Bushing	4
23	TH181-23	Pinion Gear (R.H.)	1	62	TH181-62	Hex Bolt M8x65	2
24	TH181-24	Dust Cover Assembly	2	63	TH181-63	Hex Bolt M8x50	2
25	TH181-25GM	Height Adjustment Assy	1	64	TH181-64	Hub Cap	2
26	TH181-26	Clevis Pin Ø6x37	4	65	TH181-65	Hex Bolt M6x35	4
27	TH181-27	Wing Knob	1	66	TH181-66	Height Adj. Strap Spacer	1
28	TH181-28	Washer	2	67	TH181-67	Nylon Lock Nut M10	2
29	TH181-29	Hex Lock Nut M8	12	68	TH181-68	Hex Bolt M5x25	6
30	TH181-30	Slotted Pan Head Screw M5x12	14	69	TH181-69	Big Flat Washer Ø8	1
31	TH181-31	Retainer Brush	6	70	TH181-70	Hex Bolt M6x20	12
32	TH181-32	Height Adjustment Strap	1	71	TH181-71	Retainer Brush	12
33	TH181-33GM	Hitch Tube (R.H.)	1	72	TH181-72	Hitch Pin	1
34	TH181-34GM	Hitch Bracket	1	73	TH181-73	Cotter Bearing	2
35	TH181-35GM	Hitch Bracket (Straight)	1	74	TH181-74	R Pin Ø3	5
36	TH181-36GM	Hitch Tube (L.H.)	1	75	TH181-75	R Pin Ø2	4
37	TH181-37	Big Flat Washer Ø10	4	76	TH181-76	Big Flat Washer	1
38	TH181-38	Hex Bolt M10x85	2	77	TH181-77	Hex Bolt M8x20	1
39	TH181-39	Nylon Lock Nut M5	20				

**NOTE:** Parts Lists are supplied for information purposes only, not all parts are stocked individually & we recommend you contact our Spares Team on 01793 333212 for expert advice.

# GJ HANDY & CO LTD USER WARRANTY POLICY

## Users Statement of Warranty

Each new machine is warranted against defective material or assembly of material under normal usage. The warranty applies to the original purchaser and covers faulty parts and the labour involved in replacing and repairing those parts, which are of original manufacture.

## Period of Warranty

### Webb (excludes Electric Handheld, Dynamic, Heritage, Legacy), Webb Pro, Sanli Engine

- a) 2 years from the original date of sale to the first domestic user.
- b) 90 days from the original date of sale to the professional/commercial user.
- c) 90 days from the original date of sale when used for hire.
- d) A reduced warranty period of 90 days applies to those items which are subject to normal wear and tear (e.g. but not limited to wheels, tyres, cutter bars, cylinders, cutting blades, blade boss, belts, cables, nylon line & spool, collection bags, spark plugs).
- e) Engines are supplied with a separate warranty to the machine. The engine manufacturers warranty statement which will be supplied within the engine instruction manual. All enquiries and warranty repairs should be discussed with the engine manufacturer or approved warranty repair dealer.
- f) 90 days from the original date of purchase for Replacement Spare Parts (unless normal wear & tear component, which are covered for 30 days).
- g) All machines' must be serviced within the first 12 months from the original date of purchase to comply with the warranty, failure to do so will invalidate the 2nd year of the warranty.

### Webb Electric Handheld, Webb Dynamic, Heritage & Legacy, Handy, Mowerland, Q-Garden

- a) 1 year from the original date of sale to the first domestic user.
- b) 90 days from the original date of sale to the professional/commercial user.
- c) 90 days from the original date of sale when used for hire.
- d) A reduced warranty period of 90 days applies to those items which are subject to normal wear and tear (e.g. but not limited to wheels, tyres, cutter bars, cylinders, cutting blades, blade boss, belts, cables, nylon line & spool, collection bags, spark plugs).
- e) Engines are supplied with a separate warranty to the machine. The engine manufacturers warranty statement which will be supplied within the engine instruction manual. All enquiries and warranty repairs should be discussed with the engine manufacturer or approved warranty repair dealer.
- f) 90 days from the original date of purchase for Replacement Spare Parts (unless normal wear & tear component, which are covered for 30 days).

All warranty repairs must be undertaken by an authorised service dealer. These dealers have been accredited by GJ Handy & Co Ltd and agree to only use genuine parts and follow our repair procedures.

## Not covered by this warranty

- a) The warranty policy does not cover any depreciation or damages caused by ordinary wear, rusting or corrosion, lack of correct maintenance or operation, misuse, abuse, lack of transportation or accident.
- b) The warranty policy does not cover any costs necessary for the standard periodic maintenance services instructed by the operator's manual, or service parts replacement which would include oil, filters, tyres, belts, brake linings, fuses, blades, seals and other service parts unless it can be proven that the item has evidence of faulty manufacture.
- c) The warranty policy will not cover failure or damage caused as a result of parts or accessories being modified without the written approval of GJ Handy & Co Ltd.
- d) The warranty policy will not cover the unit if non-genuine parts have been fitted and as a result damage has occurred to the unit.
- e) The warranty policy is non-transferable and is only applicable to the original purchaser.

**Disclaimer**

- a) This warranty is only a remedy for defect of products. GJ Handy & Co Ltd will never warranty in terms of the merchantability or the fitness for a particular purpose.
- b) No person is authorised to make any warranties, representations or promises, expressed or implied, on behalf of GJ Handy & Co Ltd, or to modify the terms conditions or limitation of this warranty policy in any way.
- c) Neither GJ Handy & Co Ltd nor any company affiliated with GJ Handy & Co Ltd shall be liable in any event or manner whatsoever for incidental or consequential damages or injuries, including, but not limited to, loss of crops, loss of profit, out of pocket expenses or profits, rental of substitute equipment or other commercial losses.

**General**

- a) Most warrantable failures show up within the first few weeks of use. These failures are usually straightforward and warranty assessment is relatively easy.
- b) Failures relating to cutter decks and belts need careful investigation, as the cause may not always be straightforward. Look for damage to blades and pulleys especially when the cutter belt or blade boss have snapped or cracked as this could be due to impact damage.
- c) Customers should always refer to the operator/instruction manual when any disputed problem arises, you will find most areas covered within the manual.



**For spares or support of your handy product,  
please contact us:**

**Tel: 01793 333212**

**Email: [customerservice@handydistribution.co.uk](mailto:customerservice@handydistribution.co.uk)  
(Mon – Fri 8.00am to 5.30pm excl. Bank Holidays)**

**To see our range of garden machinery & equipment visit:**

**[www.thehandy.co.uk](http://www.thehandy.co.uk)**

**Making gardening easier & affordable since 1938**

Distributed by Handy Distribution, Murdock Road, Dorcan, Swindon, SN3 5HY